

## TSP, TSFP, TSSP: Pneumatic room-temperature controllers

### How energy efficiency is improved

Enables energy-efficient control of the room temperature in pneumatic installations. The room temperature can be set precisely with the setpoint adjuster.

### Areas of application

Continuous temperature measurement and control, e.g. in air-conditioning systems. Activation of volume flow controllers or unit valves.

### Features

- Robust bimetal sensor
- P control characteristic
- Housing 72 x 72 mm in pure-white thermoplastic
- Setpoint adjuster with +/- scale and adjustable stops for setpoint limiting
- Complies with directive 97/23/EC Art. 3.3 on pressure equipment

### Technical description

- Supply pressure 1.3 bar  $\pm$  0.1
- Time constant at 0.2 m/s air velocity approx. 7 min.
- Output pressure 0.2 - 1.0 bar
- P range  $X_p$  approx. 2 K
- Linearity 2%

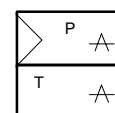

Y02125

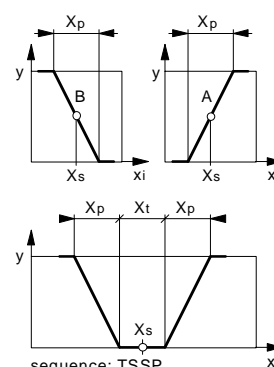

B02124b

Type	Control function 1)	Control action	Air capacity $I_n/h$	Setpoint range °C	Weight kg
TSP 80A F117	fixed-value	A	33	17...27	0,1
TSP 80B F117	fixed-value	B	33	17...27	0,1
TSP 81A F117	fixed-value	A	200	17...27	0,1
TSP 81B F117	fixed-value	B	200	17...27	0,1
TSFP 80A F117	fixed/schedule	A	33	17...27	0,1
TSFP 80B F117	fixed/schedule	B	33	17...27	0,1
TSFP 81A F117	fixed/schedule	A	200	17...27	0,1
TSFP 81B F117	fixed/schedule	B	200	17...27	0,1

### Heating-cooling sequence

TSSP 80 F117	fixed-value	A and B	2 x 33	17...27	0,1
--------------	-------------	---------	--------	---------	-----

	TSP 80, TSFP 80	TSP 81, TSFP 81	TSSP
Air consumption $I_n/h$	33	20	66
Air exhaust capacity $I_n/h$ 2)	50	34	50
External restrictor required	1 pc	–	2 pc
Dead zone $X_t$ (sequence)	–	–	2 K
Connection diagram	A02044	A02045	A02047
Fitting instructions	MV 23176/23219	MV 23184/23185	MV 23200

Supply pressure 3)	1,3 bar $\pm$ 0,1	Time constants (0,2 m/s)	approx. 7 min
Output pressure	0,2...1,0 bar	Permissible ambient temperature	0...55 °C
P-band $X_p$	approx. 2 K		
Linearity	2%	Dimension drawing	M297350
		Connection diagram and MV	see table

- 1) 'Fixed/schedule' requires an external command signal of 0...1,2 bar (e.g. RXP 81).  
Setpoint shift  $\pm$  6 K. Setpoint increase: 0,6...1,2 bar = 0...+6 K. Setpoint decrease: 0,6...0 bar = 0...-6 K
- 2) Due to the blow-off noise produced, this value should not be exceeded.
- 3) See Section 60 on regulations concerning the quality of supply air, especially at low ambient temperatures.

Архангельск (8182)63-90-72  
Астана +7(7172)727-132  
Белгород (4722)40-23-64  
Брянск (4832)59-03-52  
Владивосток (423)249-28-31  
Волгоград (844)278-03-48  
Вологда (8172)26-41-59  
Воронеж (473)204-51-73  
Екатеринбург (343)384-55-89  
Иваново (4932)77-34-06  
Ижевск (3412)26-03-58  
Казань (843)206-01-48

Калининград (4012)72-03-81  
Калуга (4842)92-23-67  
Кемерово (3842)65-04-62  
Киров (8332)68-02-04  
Краснодар (861)203-40-90  
Красноярск (391)204-63-61  
Курск (4712)77-13-04  
Липецк (4742)52-20-81  
Магнитогорск (3519)55-03-13  
Москва (495)268-04-70  
Мурманск (8152)59-64-93  
Набережные Челны (8552)20-53-41

Нижний Новгород (831)429-08-12  
Новокузнецк (3843)20-46-81  
Новосибирск (383)227-86-73  
Орел (4862)44-53-42  
Оренбург (3532)37-68-04  
Пенза (8412)22-31-16  
Пермь (342)205-81-47  
Ростов-на-Дону (863)308-18-15  
Рязань (4912)46-61-64  
Самара (846)206-03-16  
Санкт-Петербург (812)309-46-40  
Саратов (845)249-38-78

Смоленск (4812)29-41-54  
Сочи (862)225-72-31  
Ставрополь (8652)20-65-13  
Тверь (4822)63-31-35  
Томск (3822)98-41-53  
Тула (4872)74-02-29  
Тюмень (3452)66-21-18  
Ульяновск (8422)24-23-59  
Уфа (347)229-48-12  
Челябинск (351)202-03-61  
Череповец (8202)49-02-64  
Ярославль (4852)69-52-93

Единый адрес для всех регионов: [sxr@nt-rt.ru](mailto:sxr@nt-rt.ru) || [www.sauter.nt-rt.ru](http://www.sauter.nt-rt.ru)

**Accessories**

- 0228234 001\*** Setpoint adjustment knob in pure white, with raised bridge
- 0296218 000\*** Buckle-proof attachment for plug-in installation
- 0296990 000\*** Buckle-proof attachment for screw-in installation, MV 7322
- 0297441 000\*** Intermediate cover plate in pure white for various recessed junction boxes
- 0297354 000\*** Short screw-in nipple R 1/8, for soft plastic tubing of 4 mm internal diameter
- 0303124 000\*** Recessed junction box (in conjunction with 0297441, if necessary)
- 0297416 001** Housing cover in pure white, screw-type, without setpoint adjuster <sup>1)</sup>
- 0297418 032** Housing cover in pure white, screw-type, with setpoint adjuster, scale 17...27 °C <sup>1)</sup>
- 0297419 001** Housing cover in pure white, of light metal, w/o setpoint adjuster, w/o airing louvres <sup>1)</sup>
- 0297546 001** Housing cover in pure white, of light metal, w/o setpoint adjuster, w/o airing louvres <sup>1)</sup>
- 0297555 001\*** Intermediate cover plate in pure white, for large recessed junction boxes (e.g USA)
- 0297560 001\*** Intermediate cover plate in pure white for panels, for covering large holes
- 0297557 000\*** Wall insulation; prevents imprecision due to draughts from the wall
- 0297760 001** Temperature other than 22 °C for middle of scale (span ± 5 K)
- 0297760 002** Setpoint shift other than ± 6 K or 1 K per 0,1 bar (for 'fixed/schedule' types only)
- 0369573 001\*** Surface junction box, pure white
- 0369573 002\*** Surface junction box, black

<sup>\*)</sup> Dimension drawing or wiring diagram are available under the same number

<sup>1)</sup> For orders with controller, the housing will be replaced in the factory.

**Operation**

**'Fixed-value' basic function: TSP 80 & TSP 81**

The bimetal sensor, which works on the bleed-off force-balance principle, converts the temperature within its P-band into a pneumatic standard signal of 0,2 to 1,0 bar.

Direction of operation A: the output pressure increases as the temperature rises.

Direction of operation B: the output pressure decreases as the temperature rises.

When the temperature is rising, the bimetal strip bends and, via the force-balance lever, exerts a force on the nozzle-ball system. An output pressure – proportional to the force of the lever – builds up between the external pre-valve and the nozzle-ball system. On the model with direction of operation B, the nozzle-ball system is on the other side of the lever.

Instead of the external pre-valve, the models with type number 81 have an integrated pre-amplifier for systems with long lines or for drives with short running times; these require a connection for supply pressure.

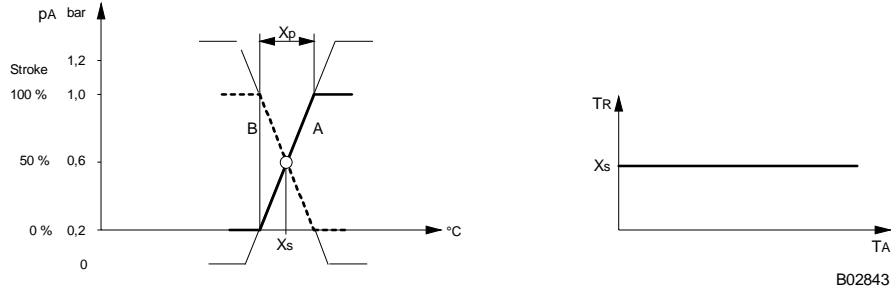

**'Fixed-value + schedule' extra function: TSFP 80 & TSFP 81**

On this model is a membrane cell below the force-balance lever. When this is pressurised by an external command signal, the setpoint  $X_s$  can be shifted. When the command signal is 0,6 bar, then control is performed exactly to the pre-set setpoint. The setpoint increase works on a command signal of 0,6 to 1,2 bar = 0 to +6 K; while the setpoint decrease is 0,6 to 0 bar = 0 to -6 K. Models with this setpoint shift have an 'F' in the model code and require a connection for command pressure.

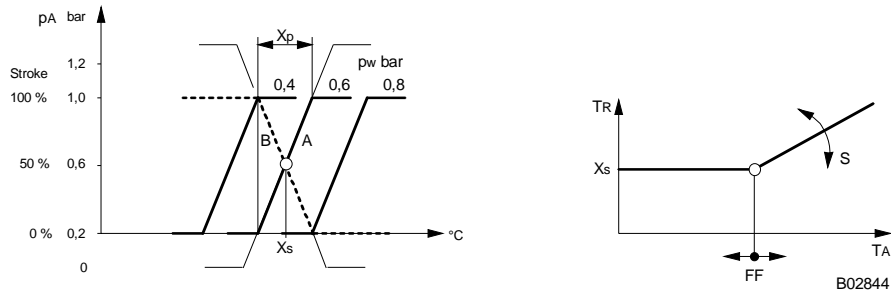

**'Sequence' extra function: TSSP 80**

This model has a nozzle-ball system on both sides of the force-balance lever. It requires two external pre-valves and has two outputs: one each for both directions of operation (A and B). This provides a sequence curve with the setpoint in the middle of the neutral zone  $X_t$ . Models with the sequence function have an additional 'S' in the model code.

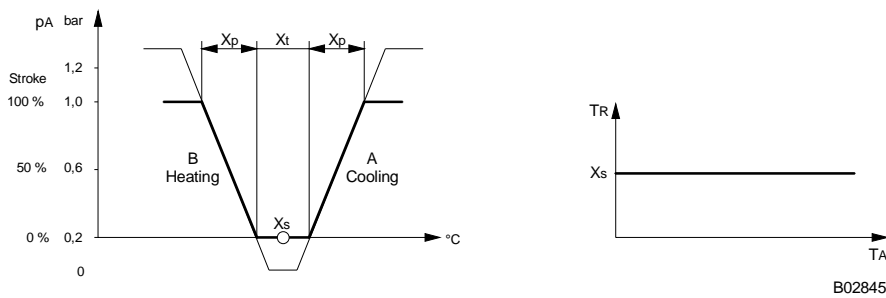
**Key**

S	= slope, setpoint shift	$T_R$	= room temperature
FF	= shift starting point, setpoint of the scheduling relay	$X_p$	= P-band
$X_S$	= setpoint	$X_t$	= dead zone
$T_A$	= outside temperature	$p_A$	= output pressure
		$p_W$	= command pressure

**Engineering notes**

In order to prevent excess noise, the air recovery should be kept to 50 l<sub>n</sub>/h for the TS. P 80 and 34 l<sub>n</sub>/h for the TS. P 81. This means that the maximum number of RLP units that can be connected to each controller is as follows:-

TS. P 80: either three RLP 10 or 20, or three RLP 100 F00.

TS. P 81: either two RLP 10 or 20, or two RLP 100 F00.

On installations with a re-heater that have been equipped with a sequence relay or sequence-reversing relay (air supplied by the RLP), the air emitted at terminal 6 of the RLP is bled off by the sequence relay or sequence-reversing relay so that no such noise is caused by the TS. P 8 unit itself. The maximum air recovery of a sequence relay or sequence-reversing relay is 50 l<sub>n</sub>/h.

For this reason, no more than three RLP units may be connected to such a relay. If more are connected (to either a sequence relay or sequence-reversing relay or a TS. P 8 unit), an interface relay XRP 101 must be used.

**Additional details on accessories**

- 0297419 001** Housing cover in pure white, of light metal, screw-type, without setpoint adjuster, without airing louvres, time constant 10 instead of 7 minutes.
- 0297546 001** Housing cover in pure white, of light metal, screw-type, without setpoint adjuster, with straight airing louvres, time constant approx. 7 minutes.
- 0297555 001** Intermediate cover plate in pure white, for large recessed junction boxes (e.g USA); includes fitting ring and two screws (M3 × 6, M4 × 16)
- 0297760 001** Setting limits: middle of scale 15 –40 °C; end of scale 10 –45 °C  
For special settings, use full °C values only.
- 0297760 002** The command pressure can be set between 0 and 1,2 bar. The variable setpoint shift is either 0,5 °C or 0,75 °C per 0,1 bar.

**Additional details on models**

Housing cover of plastic with slanted air louvres, or metal (see Accessories). Internal setpoint adjustment with end stops and '+ -' scale.

Base plate for snap-on or screw-on housing cover with two Allen-type grub screws (1,5 mm). Types TSP 81 and TSFP 81 have quantity amplification.

Types TSFP 80, TSFP 81 and TSFWP 80 have a connection piece with a membrane for the setpoint shift. Measurement connection for tube of Ø 1,8 × 3,5 mm.

**Connection diagrams**

TSP 80, TSFP 80

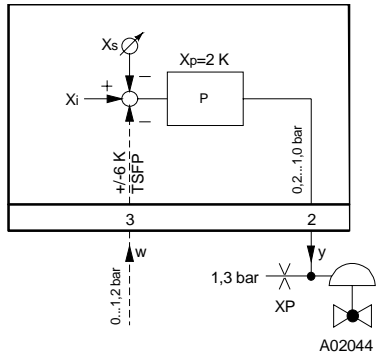

TSP 81, TSFP 81

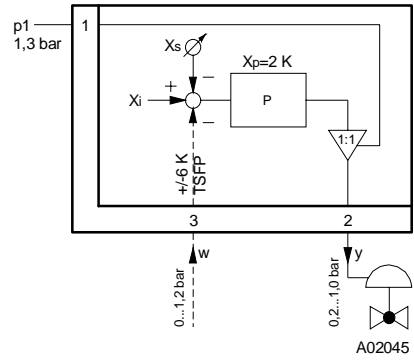

TSSP 80

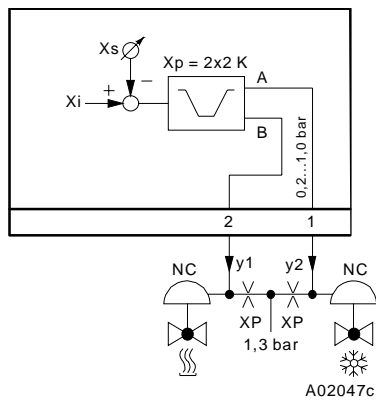

Use NC valves (normally closed)  
(e.g. VK18P or BK18P)

**Dimension drawing**

TS . P 80

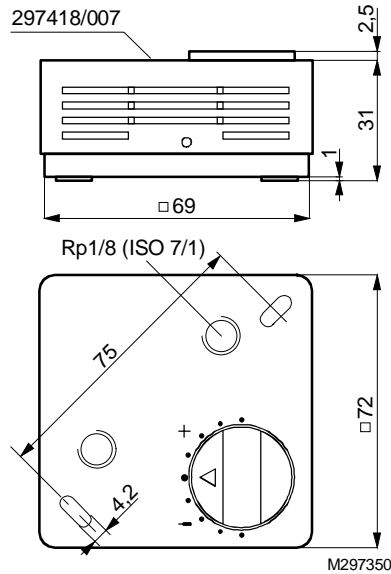

TS . P 81

Accessories

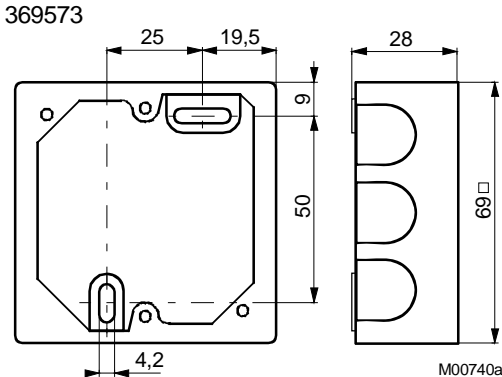
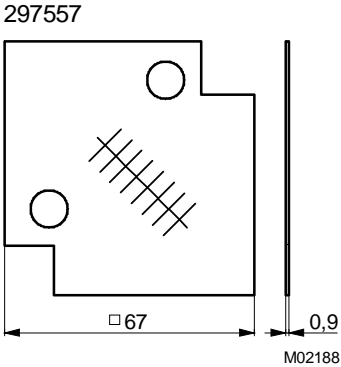
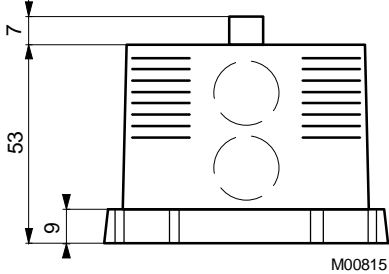
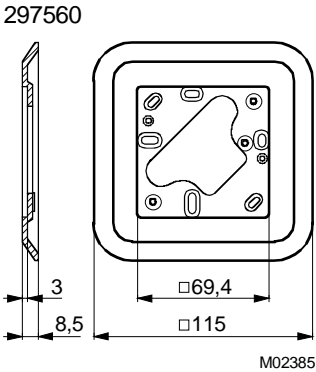
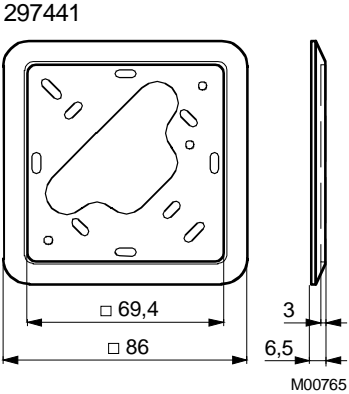
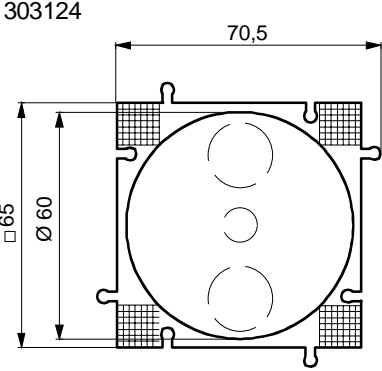
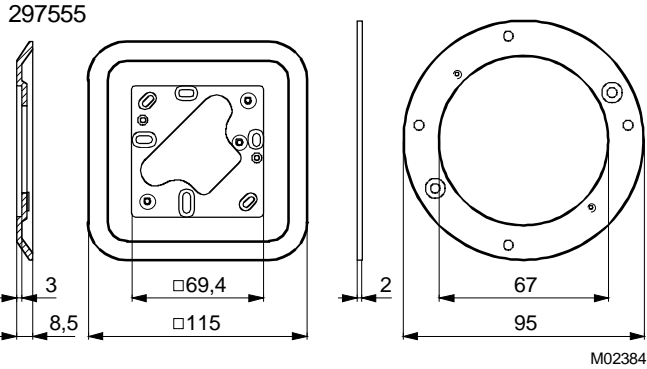
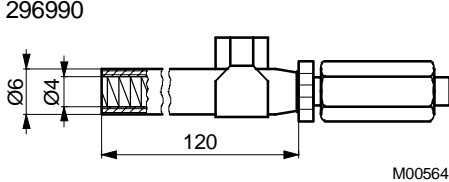
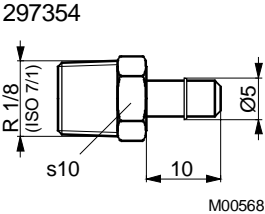
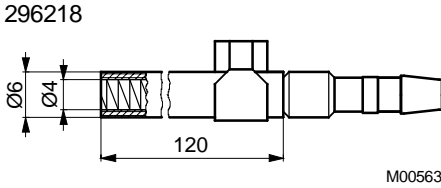
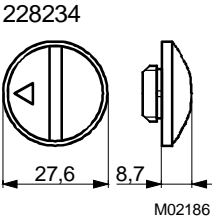

Engineering and fitting notes

To connect the air lines, the short screw-in piece (0297354) must be used. Where space is limited, the use of the buckle-proof adaptor is recommended.

Panel fitting

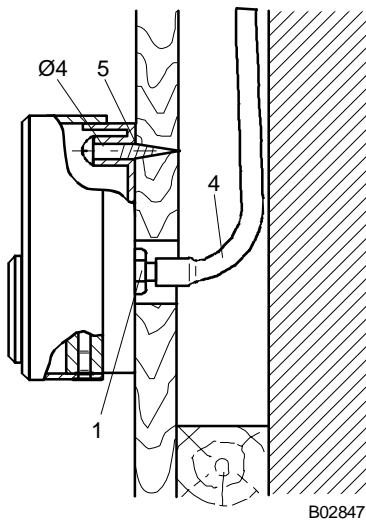

B02847

Surface fitting

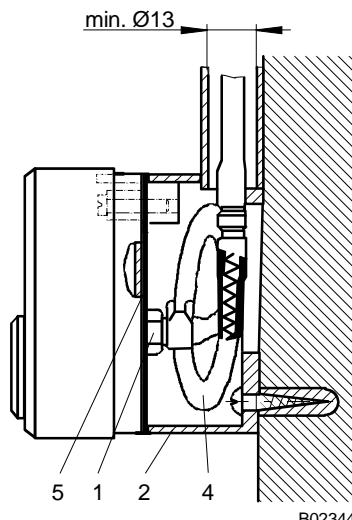

B02344

Recessed fitting

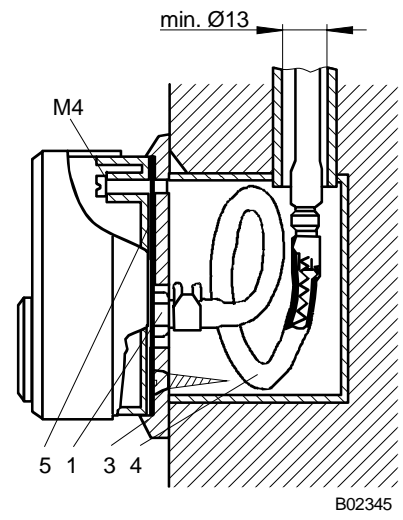

B02345

- 1 Short screw-in piece (0297354)
- 2 Surface junction box, pure white
- 3 Intermediate cover plate (0297441)
- 4 Buckle-proof adaptor, plug-in type (0296218)  
Buckle-proof adaptor, screw-in type (0296990)
- 5 Wall seal (0297557)

Panel fitting on partition walls (plaster board) with large opening for the compressed-air tube.

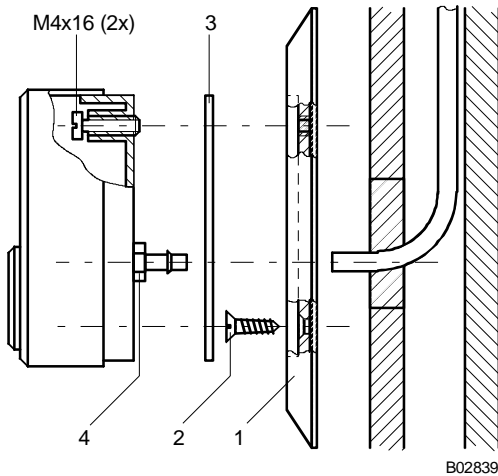

B02839

Recessed fitting with large recessed junction box (e.g. for USA)

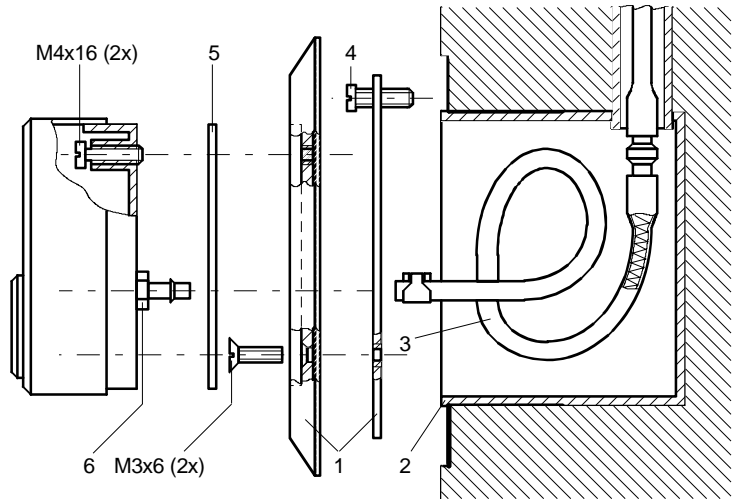

B02840

- 1 Intermediate cover plate incl. M 4 × 16 (21) (0297560/001)
- 2 Screws Ø 3,5 (2 ×); not supplied
- 3 Wall seal (0297557)
- 4 Short screw-in piece (0297354)

- 1 Intermediate cover plate incl. M 3 × 6 (2×) and fitting ring 0297555/001
- 2 Recessed junction box; not supplied
- 3 Buckle-proof adaptor, plug-in type (0296218)
- 4 Screws; not supplied
- 5 Wall seal (0297557)
- 6 Short screw-in piece (0297354)

### Examples of use

- Feeding a command variable (outside temperature) to several room-temperature controllers of type TSFP. 80, 81

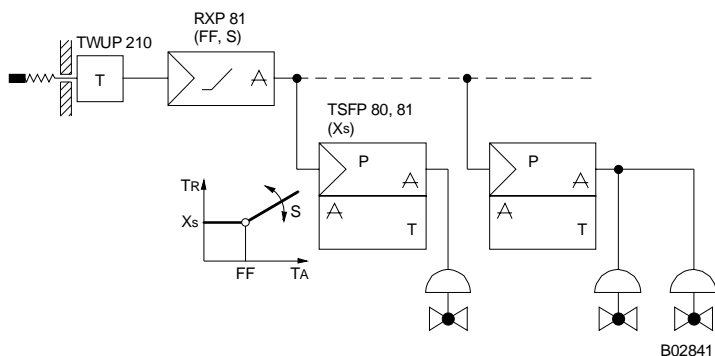

- Feeding a command variable (outside temperature) to a room-temperature controller of type TSSP 80 with two outputs (heating/cooling) for twin-circuit VAV control with several VAV controllers.

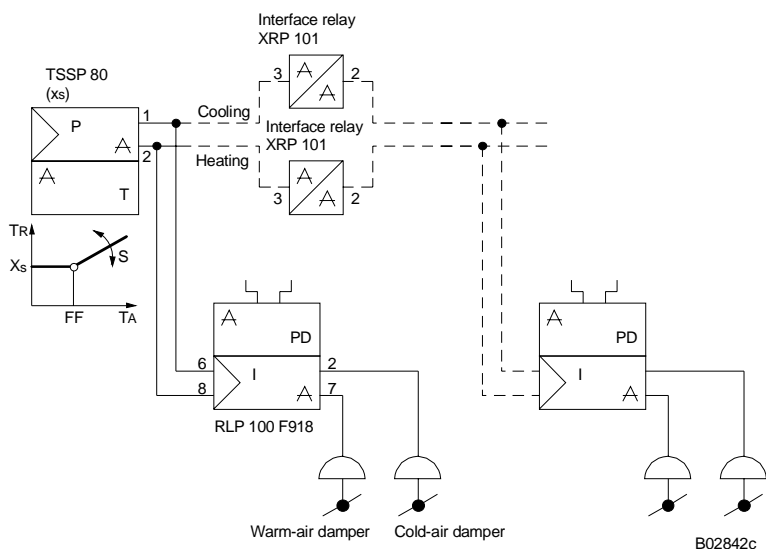

Архангельск (8182)63-90-72  
 Астана +7(7172)727-132  
 Белгород (4722)40-23-64  
 Брянск (4832)59-03-52  
 Владивосток (423)249-28-31  
 Волгоград (844)278-03-48  
 Вологда (8172)26-41-59  
 Воронеж (473)204-51-73  
 Екатеринбург (343)384-55-89  
 Иваново (4932)77-34-06  
 Ижевск (3412)26-03-58  
 Казань (843)206-01-48

Калининград (4012)72-03-81  
 Калуга (4842)92-23-67  
 Кемерово (3842)65-04-62  
 Киров (8332)68-02-04  
 Краснодар (861)203-40-90  
 Красноярск (391)204-63-61  
 Курск (4712)77-13-04  
 Липецк (4742)52-20-81  
 Магнитогорск (3519)55-03-13  
 Москва (495)268-04-70  
 Мурманск (8152)59-64-93  
 Набережные Челны (8552)20-53-41

Нижний Новгород (831)429-08-12  
 Новокузнецк (3843)20-46-81  
 Новосибирск (383)227-86-73  
 Орел (4862)44-53-42  
 Оренбург (3532)37-68-04  
 Пенза (8412)22-31-16  
 Пермь (342)205-81-47  
 Ростов-на-Дону (863)308-18-15  
 Рязань (4912)46-61-64  
 Самара (846)206-03-16  
 Санкт-Петербург (812)309-46-40  
 Саратов (845)249-38-78

Смоленск (4812)29-41-54  
 Сочи (862)225-72-31  
 Ставрополь (8652)20-65-13  
 Тверь (4822)63-31-35  
 Томск (3822)98-41-53  
 Тула (4872)74-02-29  
 Тюмень (3452)66-21-18  
 Ульяновск (8422)24-23-59  
 Уфа (347)229-48-12  
 Челябинск (351)202-03-61  
 Череповец (8202)49-02-64  
 Ярославль (4852)69-52-93

Единый адрес для всех регионов: [sxr@nt-rt.ru](mailto:sxr@nt-rt.ru) || [www.sauter.nt-rt.ru](http://www.sauter.nt-rt.ru)