

RLP 100: Pneumatic air-volume controller

How energy efficiency is improved

Enables the demand-led volume flow control of fume cupboards, laboratory rooms and clean rooms.

Areas of application

Specially designed for volume flow control equipment in VAV installations. In combination with a highly accurate, static differential pressure transmitter and a pneumatic damper drive, it is possible to control laboratory fume cupboards, laboratory rooms and room pressures.

Features

- ATEX certification for use in Zone 1 potentially explosive areas
- Conformity tested as per EN 13463-1 and EN 1127-1 (Ex II 2 G T6)
- Control of constant, switchable or variable air volumes
- Highly accurate, static differential pressure sensor with large measuring range (1 to 160 Pa)
- Controller front panel is printed with circuit diagram for rapid identification of function
- Glass-fibre-reinforced thermoplastic housing suitable for wall or top-hat rail mounting (rail EN 60715)
- Compressed-air connections with Rp 1/8" female thread
- Special measuring connection for recording the volume flow with M4 connector
- Low-pressure connections in form of stepped nipples for flexible plastic hose (internal Ø 4 and 6 mm)
- Complies with directive 97/23/EC Art. 3.3 on pressure equipment

Technical description

- Supply pressure 1.3 bar ± 0.1
- Response sensitivity of sensor 0.1 Pa
- Linearity, square root extraction accuracy 2%
- Two inputs for:
 - command variable
 - setpoint adjustment $\Delta \dot{V}$
- Two outputs for:
 - actual value
 - activation of damper drive
- One adjuster for adjustment of the sensor measuring range
- Three setpoint adjusters for maximum and minimum limiting of volume flow, plus limiting setpoint adjustment ΔV to max. ± 20%

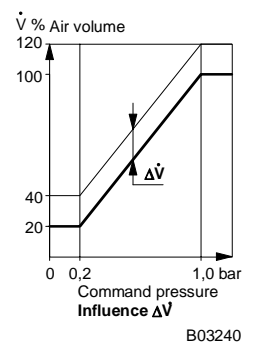
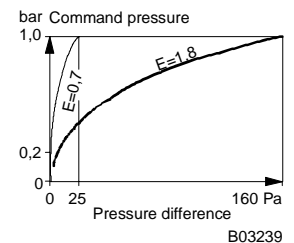
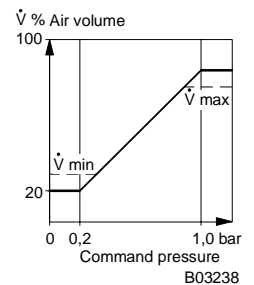
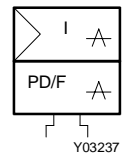

Type	Control action	Setpoint-shift $\Delta \dot{V}$ % \dot{V}	Sequence relay	Air capacity I_n/h	Weight kg
For supply air and return air (room-air control, integral)					
RLP 100 F003	B/A	3...20	–	330	0,6
For return air in aggressive gases (fume-cupboard control, PI)					
RLP 100 F123	A	–	–	900	0,6
For return air in aggressive gases (room-air control, integral)					
RLP 100 F914	A	3...20	–	330	0,6
For supply air and return air, with interface relay (room-air control, integral)					
RLP 100 F919	A	–	–	330	0,6
Output pressure	0,2...1,0 bar		Reset time, F123		1 s
Setpoint range for air volume	20...100% \dot{V}		Input: setpoint shift w_1		20...100% \dot{V}
Measuring range Δp (factory setting) reducible to	6,4...160 Pa 1...25 Pa		Usable range p_{stat}		0...3000 Pa
Response sensitivity	0,1 Pa		Permissible pressure (low-pressure connections)		3000 Pa
Linearity; root extraction ²⁾	2%				
Supply pressure ³⁾	1,3 bar ± 0,1		Connection diagram		
Air consumption	44 I_n/h		F003	A02878	
F123	90 I_n/h		F914, F123	A02879 ; A07495	
with setpoint shift $\Delta \dot{V}$	60 I_n/h		F919	A08621	
Permissible ambient temp.	0...55 °C		Dimension drawing	M297570	
Type of protection	IP 30		Fitting instructions	MV 505804	
			F123	MV 505546	
			F914; F919	MV 505337 ; MV 505263	

Архангельск (8182)63-90-72
 Астана +7(7172)727-132
 Белгород (4722)40-23-64
 Брянск (4832)59-03-52
 Владивосток (423)249-28-31
 Волгоград (844)278-03-48
 Вологда (8172)26-41-59
 Воронеж (473)204-51-73
 Екатеринбург (343)384-55-89
 Иваново (4932)77-34-06
 Ижевск (3412)26-03-58
 Казань (843)206-01-48

Калининград (4012)72-03-81
 Калуга (4842)92-23-67
 Кемерово (3842)65-04-62
 Киров (8332)68-02-04
 Краснодар (861)203-40-90
 Красноярск (391)204-63-61
 Курск (4712)77-13-04
 Липецк (4742)52-20-81
 Магнитогорск (3519)55-03-13
 Москва (495)268-04-70
 Мурманск (8152)59-64-93
 Набережные Челны (8552)20-53-41

Нижний Новгород (831)429-08-12
 Новокузнецк (3843)20-46-81
 Новосибирск (383)227-86-73
 Орел (4862)44-53-42
 Оренбург (3532)37-68-04
 Пенза (8412)22-31-16
 Пермь (342)205-81-47
 Ростов-на-Дону (863)308-18-15
 Рязань (4912)46-61-64
 Самара (846)206-03-16
 Санкт-Петербург (812)309-46-40
 Саратов (845)249-38-78

Смоленск (4812)29-41-54
 Сочи (862)225-72-31
 Ставрополь (8652)20-65-13
 Тверь (4822)63-31-35
 Томск (3822)98-41-53
 Тула (4872)74-02-29
 Тюмень (3452)66-21-18
 Ульяновск (8422)24-23-59
 Уфа (347)229-48-12
 Челябинск (351)202-03-61
 Череповец (8202)49-02-64
 Ярославль (4852)69-52-93

Accessories

0297354 000*	Short screw-type connector R $\frac{1}{8}$ for soft plastic tubing, internal \varnothing 4 mm; F003, F919: 4 pcs required, F123, F914: 5 pcs required
0297653 000	Resistor 10 Ω f, for air capacity of 180 l _n /h (not for F123)
0297762 001	Restrictor \varnothing 0,8 mm for attenuating turbulent low-pressure signals; 2 pcs required
0274571 000	Restrictor \varnothing 0,5 mm for attenuating turbulent low-pressure signals; 2 pcs required
0297800 001*	Manual switch, Open-Closed (min. air volume), for panel mounting; A07667 , MV505784 ¹⁾
0297772 001*	Screw-in push-on adaptor M4 with seal for soft plastic tubing of \varnothing 4 mm internal
0297838 001*	Bracket for two XMP pressure gauges (see PDS, Section 68) ¹⁾
0297091 000*	Blanking piece for unused pressure-gauge aperture
0297680 001	Setpoint \dot{V} in., \dot{V} max. set and marked (not for F123)
0297680 002	Influence E set and marked
0297870 001*	Fixing bracket for fitting the controller to ceilings, floors or panels ¹⁾

*) Dimension drawing or wiring diagram are available under the same number

1) The accessories were tested for protection against explosion when fitted to the standard version of this product

Operation

RLP 100 F003

The pressure difference created at the orifice plate or dynamic pressure sensor is converted by the root-extracting transducer into a fluidic-linear standard signal (0.2...1.0 bar). The command variable w at connector 6 (e.g. TSP 80 temperature controller) is limited by the min. and max. adjuster, and is compared with the actual value. For fixed-value control, no command variable w is connected, since the 'min.' adjuster serves as the setpoint adjuster. The integral controller compensates without lasting error for the control deviation. The measuring range (as the pressure difference) is set via adjuster E ($E = 0,7...1,8$).

The use of temperature controllers without amplifier (TS.P 80 or TK.P 80) is recommended. The temperature controller is supplied by the internal restrictor (\varnothing 0,14 mm).

The value set at the $\Delta \dot{V}$ adjuster (3...20% \dot{V}) is added to the setpoint volume. It can be adjusted externally via terminal 8; the value set at the $\Delta \dot{V}$ adjuster becomes the minimum limitation.

The control action can be changed from B (factory setting) to A using the change-over switch.

Additional function for RLP 100 F914

In order to protect the measuring diaphragm from aggressive gases, a very small amount of air is fed constantly into the '+ and -' low-pressure line. For the command of, for example, a supply-air volume-flow controller by a return-air volume-flow controller (RLP 100 F914), an interface relay is fitted internally for de-coupling the pneumatic signal at terminal 7. If a passive element (e.g. a pressure gauge for showing the actual value) is connected to connector 7, it must be supplied with air by an external restrictor of 0,2 mm dia.

Additional function for RLP 100 F919

For controlling the room temperature (e.g. with a TSFP 80 F117) via a room supply- or return-air controller (RLP 100 F919), an interface relay is fitted in order to de-couple the pneumatic signal at terminal 7. If a passive element (e.g. a pressure gauge for showing the actual value) is connected to connector 7, it must be supplied with air by an external restrictor of \varnothing 0,2 mm.

RLP 100 F123

The pressure difference created at the orifice plate or dynamic pressure sensor is converted by a root-extracting transducer into a fluidic-linear standard signal (0,2...1,0 bar). The command variable (connector 6) from the sash sensor (TUP 224 F901, continuous), and the command variable (connector 8) from the sliding-door sensor (micro-switch, 2-point, EVM 131-F01-01S, manufactured by SMC) are limited by the min. and max. adjuster and compared with the actual value. The controller uses the larger of the two signals as the setpoint. The PI-controller compensates without lasting error for the control deviation. The measuring range (as the pressure difference) is set via adjuster E ($E = 0,7...1,8$). To prevent toxic gases from escaping from fume cupboards, the air volume must react within 1 to 2 seconds proportionate to the amount that the sash is opened, i.e. the damper's positioning time is short. When the sash is closed, the positioning time is about five seconds, so that no excess pressure arises in the room.

The sash sensor at terminal 6 is fed by the internal restrictor (\varnothing 0,2 mm) in the RLP. The sliding-door sensor at terminal 8 is fed by a different internal restrictor (\varnothing 0,14 mm). If connector 8 is closed, \dot{V}_{max} applies; if connector 8 is open, the controller uses the value provided by the sash sensor. If no sliding-door sensor is needed, connector 8 should not be closed off.

The output signal at terminal 7 (deviation from the command variable at connectors 6 and 8 to the actual value) amounts to $0,6 \pm 0,4$ bar and is fed to either a pressure gauge or the RXP 210 alarm unit. If the command variable (connector 6) from the sash sensor is higher than the max. limitation, the output signal at connector 7 amounts to $0,6 - 0,4$ bar.

If, in order to monitor the fume-cupboard's air volume with the RXP 210 alarm unit, a low-flow function is also required (setting a minimum air volume regardless of the sliding door's opening), then a manual switch (accessory no 0297800 001) can be fitted at terminal 6 between the TUP 224 F901 sash sensor and the RLP 100 F123. If the function 'Min. or max. air volume ($\dot{V}_{100\%}$) regardless of the sliding door's opening' is required without an alarm unit, then a manual switch (accessory no 0297800 002) can be fitted at terminal 8 between the TUP 224 F901 sash sensor and the RLP 100 F123.

In order to protect the measuring diaphragm from aggressive gases, a very small amount of air is fed constantly into the '+ and -' low-pressure line.

Additional information on accessories



0297762 001 Restrictor (\varnothing 0,8 mm) for damping turbulent low-pressure signals; push-on connector for soft plastic tubing of 4 mm internal dia. If the damping is insufficient, a \varnothing 0,5 mm restrictor can be used instead (accessory no. 0274571; not suitable for RLP 100 F908, F914, F123).

0274571 000 Restrictor \varnothing 0,5 mm) for damping turbulent low-pressure signals; push-on connector for soft plastic tubing of \varnothing 4 mm internal. Used in extreme cases where the \varnothing 0,8 mm restrictor (accessory no. 0297762) has proved to be inadequate. Unsuitable for any volume-flow controllers (RLP 100 F914 and F123) and transducers (RLP 100 F908) that have a very small amount of air fed constantly into the '+ and -' low-pressure line, since the pressure signals in the lower part of the measuring range are falsified, and the positioning time of 1...2 seconds (RLP 100 F123) is not attained.

0297800 . . . Manual switch for switching over pneumatic lines. Housing of light-grey thermoplastic. Front plate of aluminium with rotary knob. Compressed air via push-on connector for soft plastic tubing of 4 mm internal diameter. Suitable for fitting in panels.

Nominal flow Q_N 1 bar with respect to atmosphere	3,0 m ³ /h
Max. leakage rate (2,5 bar → 0)	1,2 l/h
Permissible pressure or differential pressure	2,5 bar
Ambient temperature	0...70 °C
Weight	0,05 kg
Connection diagrams	
0297800 001	A07667
0297800 002	A03322
Dimension drawing	M04091

0297800 001

Scale	Function
	continuity from 2 to 0; control mode
	continuity from 3 to 0, \dot{V}_{min}

0297800 002

Scale	Function
Aut.	continuity from 1 to 0
min	continuity from 2 to 0
Aut.	continuity from 3 to 0
max	no continuity to 0

Operation

Dial runs on O-rings, locking in either 2 or 4 positions.

Additional details on accessories

0297838 001 Bracket for two XMP pressure gauges. Includes:
 1 adaptor (0297596) for tube (internal Ø 1,7 or 4,1);
 1 Connector (0297112) with seal M4/push-on connector for tube (internal Ø 1,7);
 1 m tube (internal Ø 1,7) and 2 screws.
 Use the blanking piece (0297091) to cover the unused opening in the bracket. The pressure gauge for indicating the room pressure should be connected to the actual-value terminal M.

Technical information

Technical manual: VAV 7 000 621 003

Engineering and fitting notes

The unit should not be fitted laterally (as depicted below, right).

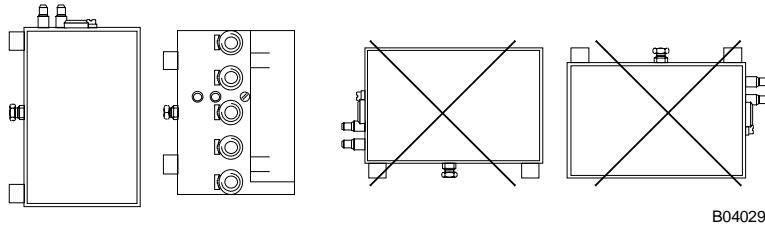

B04029

There should be no positioner connected between the integral controller and the actuator or valve drive.

The output pressure must go directly to the drive. In order to prevent turbulence which, in the form of oscillations, affects the low-pressure signal, there should be a smoothing sector in front of the measuring cross for the measurement of differential pressure.

Where the flow may be problematical – e.g. right-angles, bends or junctions directly in front of the measuring cross –, a restrictor should be fitted into the plastic tubing of the ‘+’ and ‘-’ connection in order to attenuate turbulent low-pressure signals.

Connection diagrams

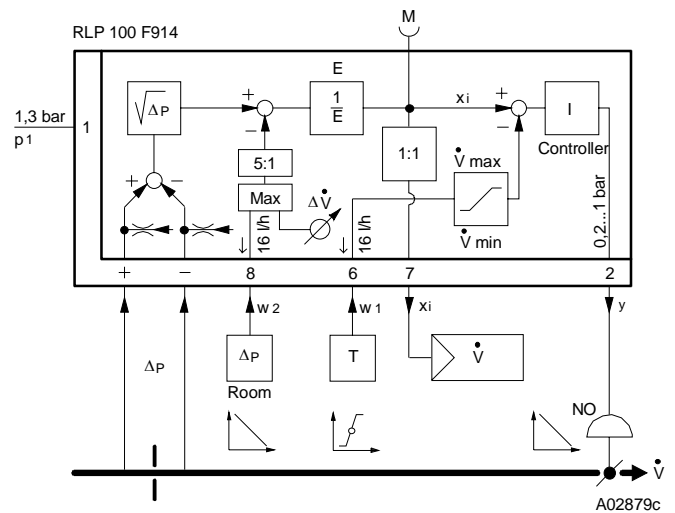
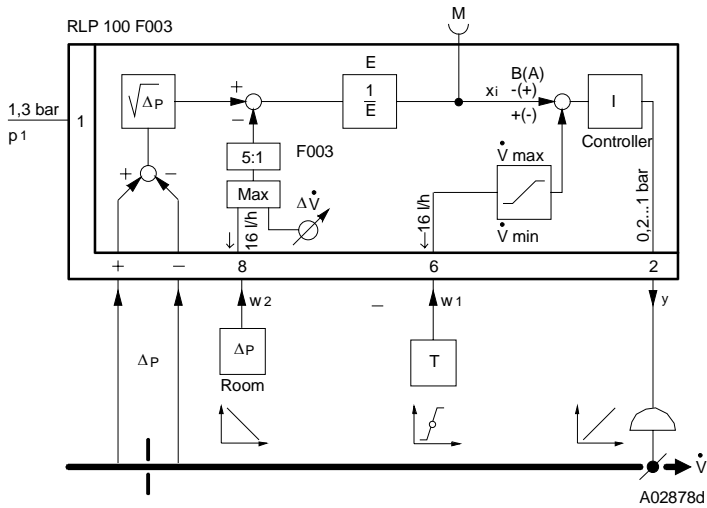

w = command variable
 Δp = pressure difference
 v̇ = output pressure

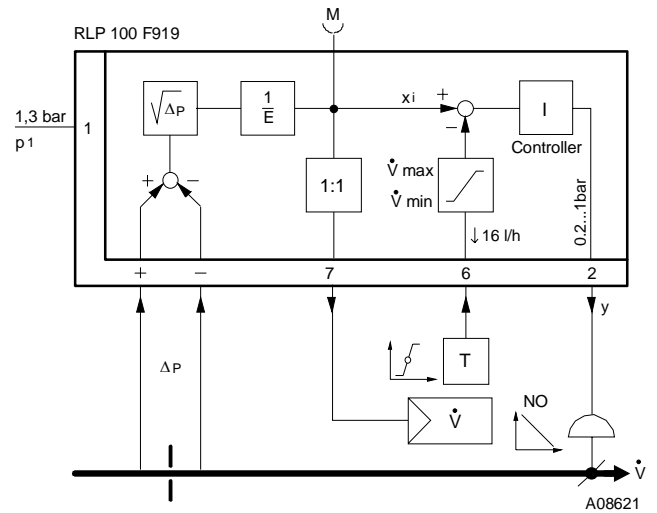
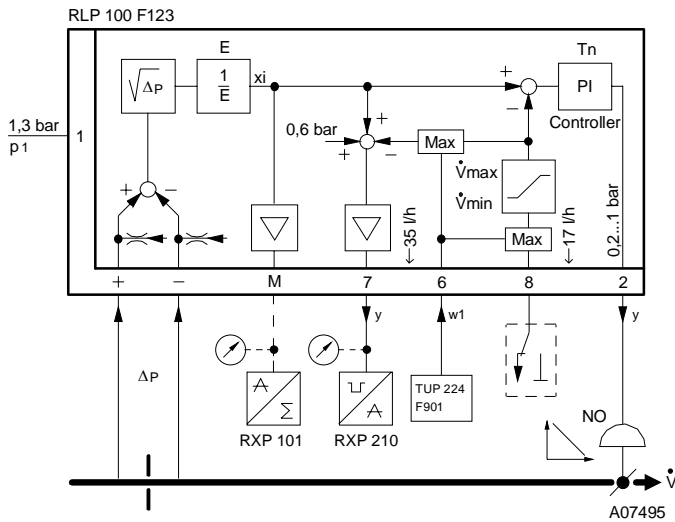

297800 001

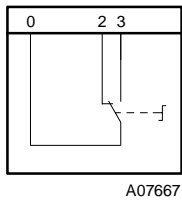

297800 002

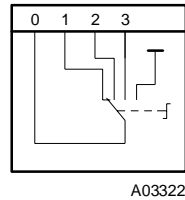

Dimension drawing

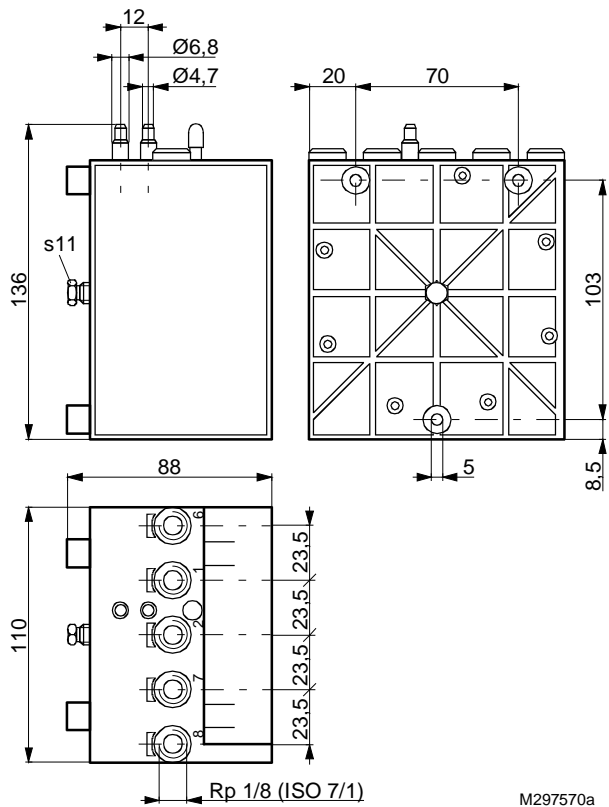

Accessories

297870 001

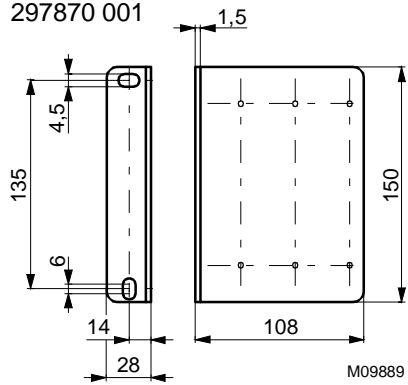

297354

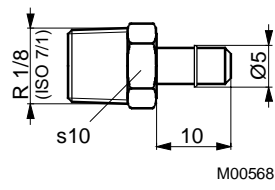

297772

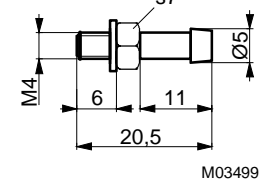

297800

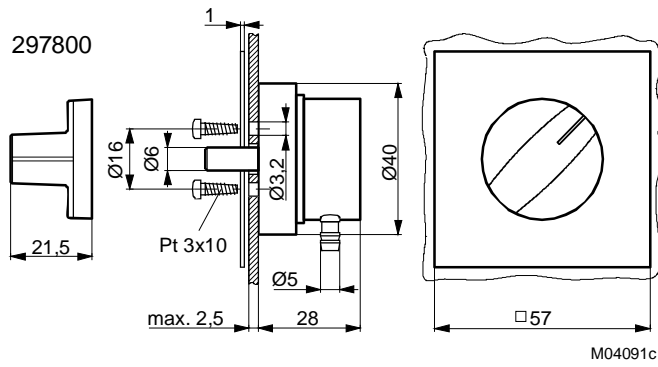

297091

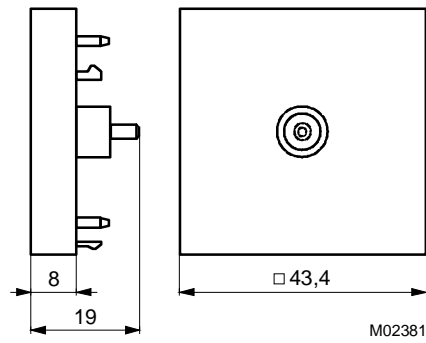

297838

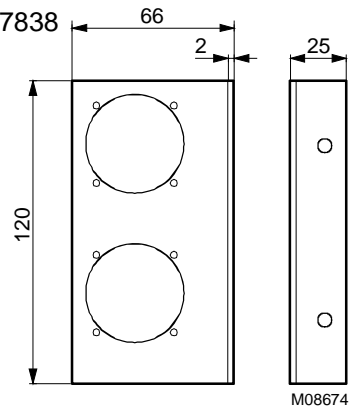

Examples of use

1. Control facility for variable air volume without re-heater, for 'open rooms'

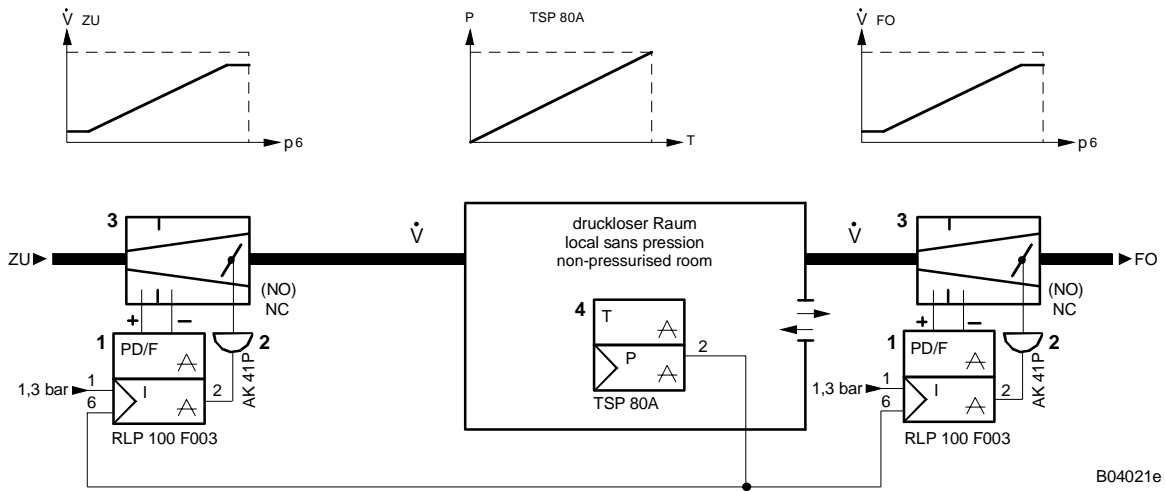

2. Control facility for variable air volume without re-heater, for 'open rooms' with over-pressure

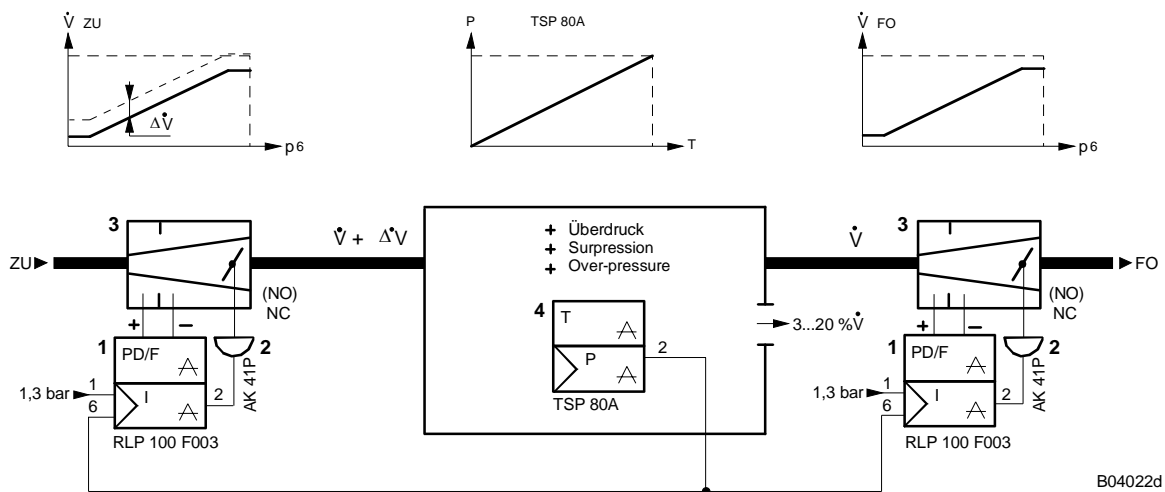

3. Control facility for variable air volume without re-heater, for 'open rooms' with under-pressure

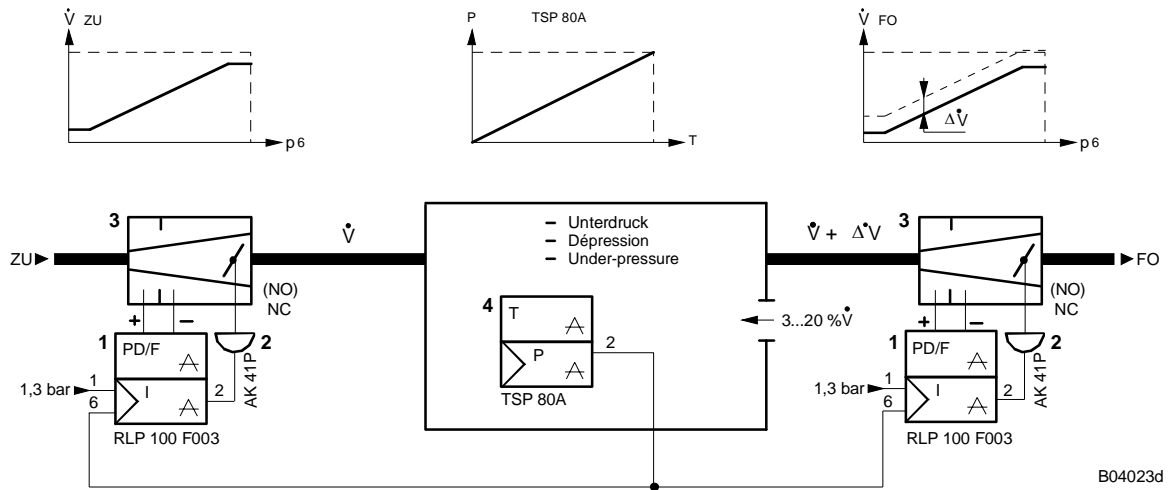

4. Control facility for variable air volume with re-heater, for 'open rooms' with dead zone, normally closed re-heater, room-temperature controller with control action A and B

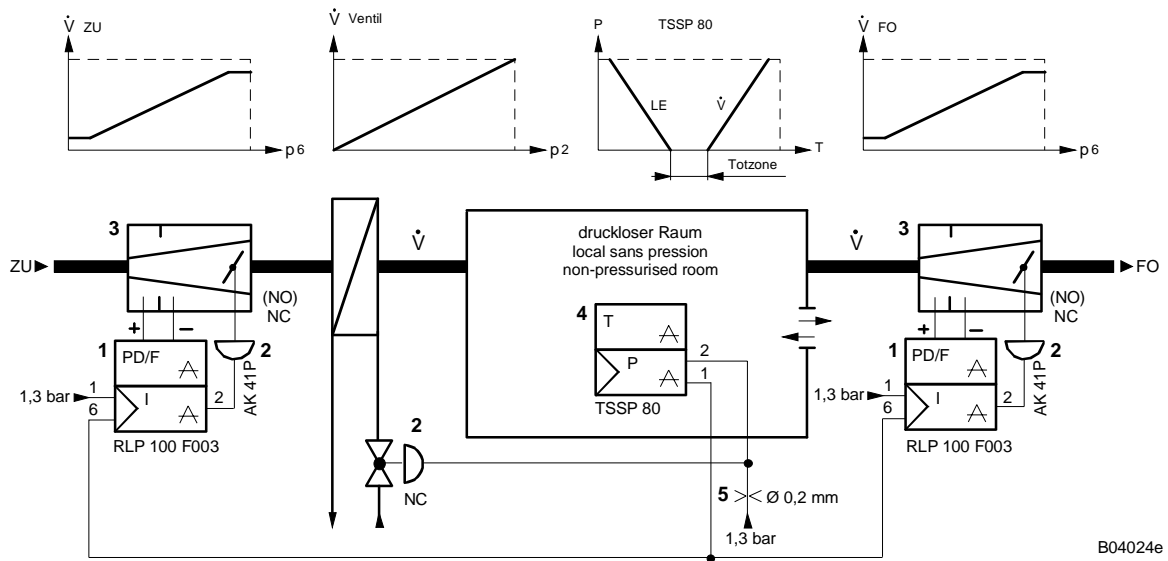

5. Control facility for variable air volume with re-heater, for 'open rooms', normally open re-heater, room-temperature controller with control action A

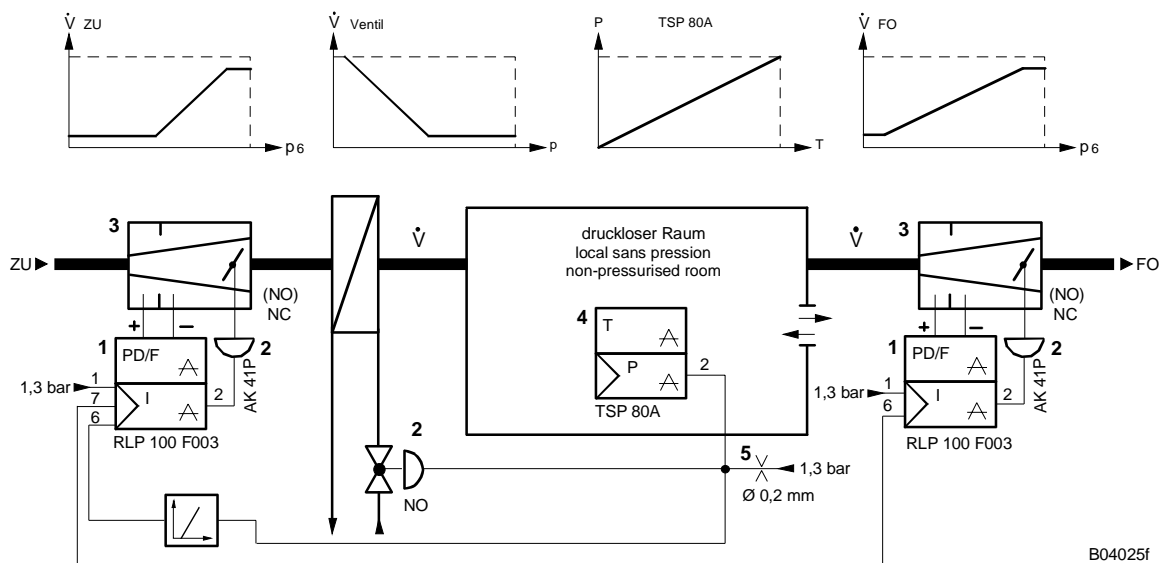

B04025f

6. Control facility for variable air volume with re-heater, for 'open rooms', normally closed re-heater, room-temperature controller with control action B

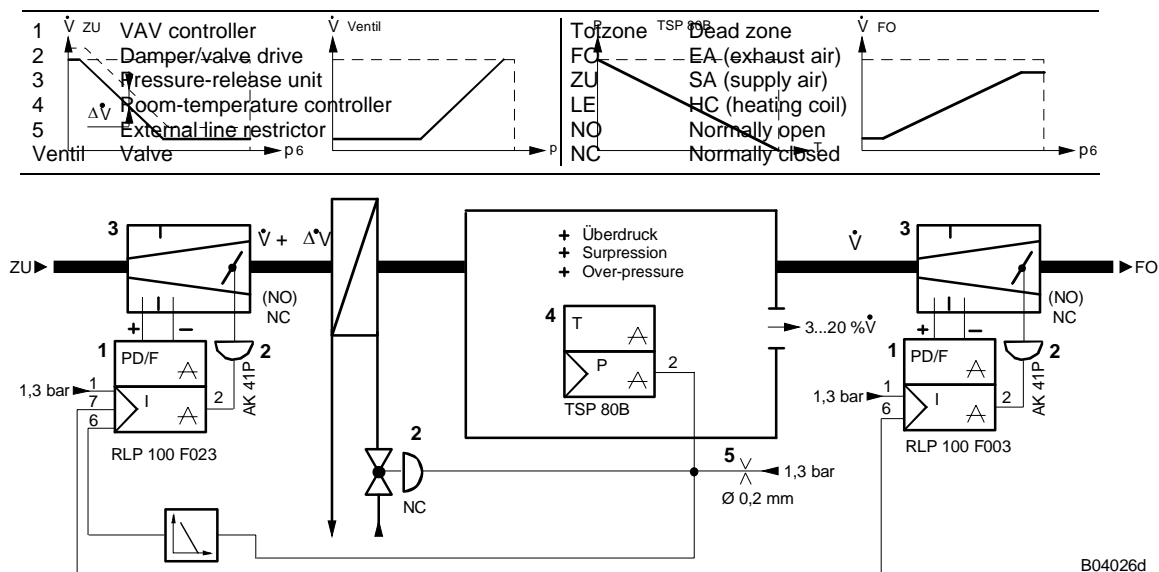

B04026d

1	VAV controller	VAV controller	Top zone	Dead zone	V-dot_FO
2	Damper/valve drive	Damper/valve drive	FC	EA (exhaust air)	
3	Pressure-release unit	Pressure-release unit	ZU	SA (supply air)	
4	Room-temperature controller	Room-temperature controller	LEI	HC (heating coil)	
5	External line restrictor	External line restrictor	NO	Normally open	
	Ventil Valve		NC	Normally closed	

7. Laboratory exhaust-air control.

Control facility for air-volume exhaust-air control (in relation to the amount that the sash is open) for fume cupboards; with sash sensor, alarm and operating unit, taking room temperature into account. Room-temperature controller is controlled by the data centre; room pressure is fed back to the data centre via an e/p/p/e transducer.

Engineering note: Laboratory exhaust-air control is also possible with Sauter's EY3600 ecos system. This allows more data points to be transmitted, but the damper drives and the sliding door's sensing system have a shorter serviceable life, while the control system has a longer positioning time (> 15 sec).

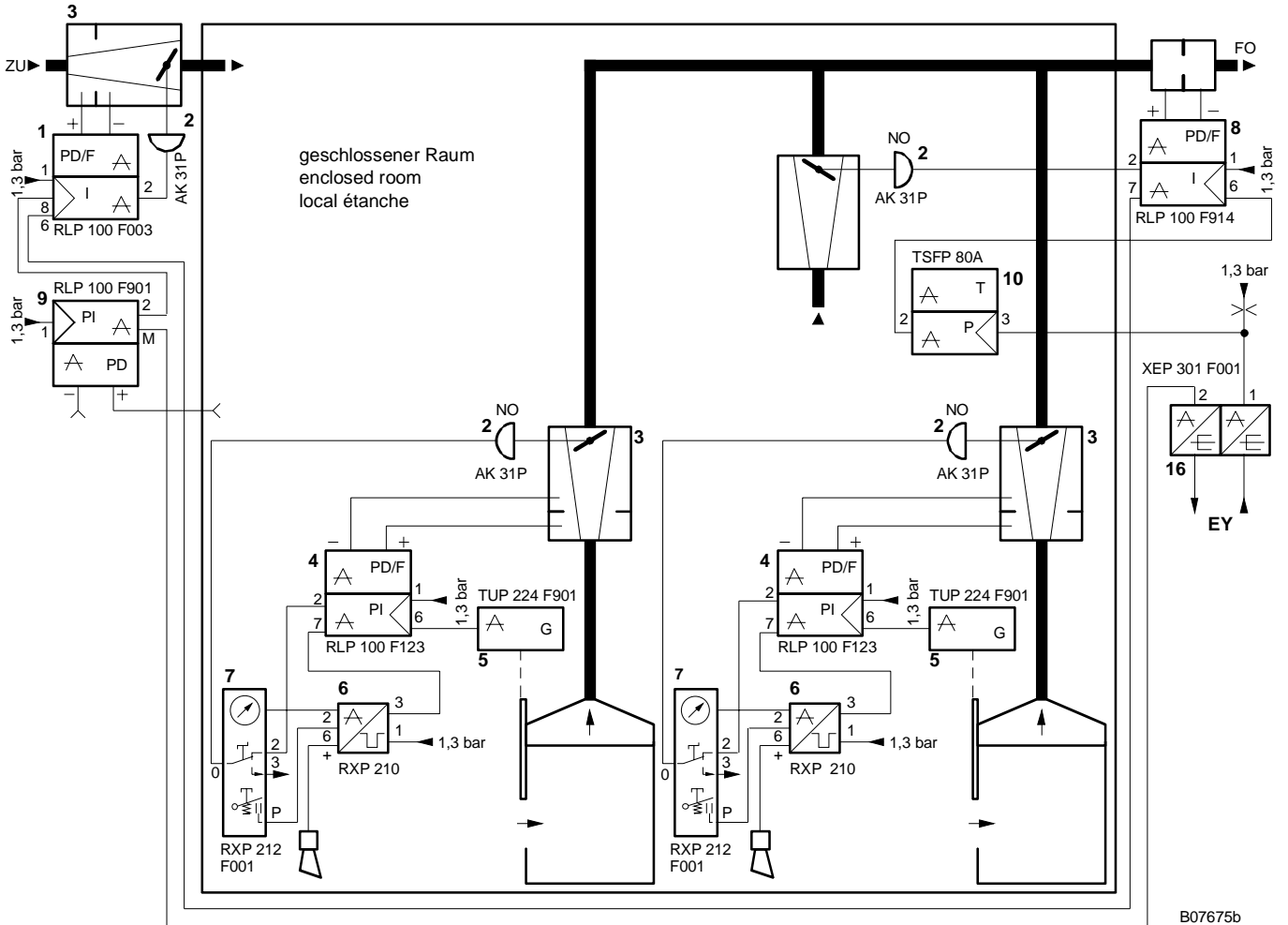

Variant: RLP 100 F123
 with: alarm unit RXP 210 and
 operating unit RXP 212 F003
 (manual switch $\text{Aut}-\dot{V}_{\min}-\text{Aut}-\dot{V}_{\max}$)

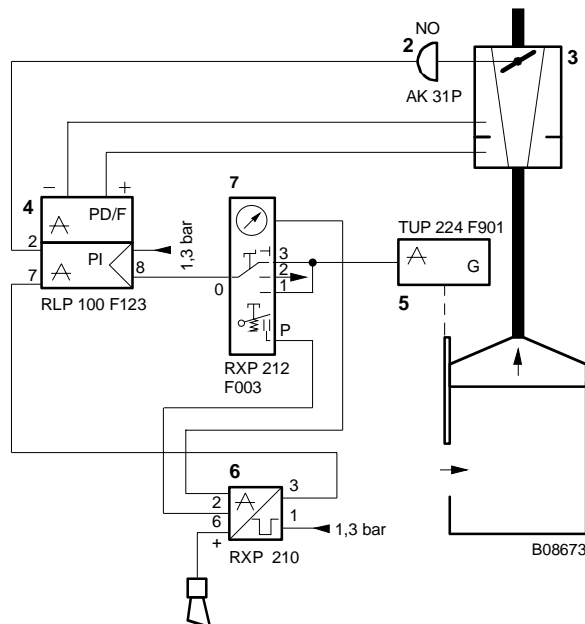

Variant: RLP 100 F123
with: manual switch, min. air volume

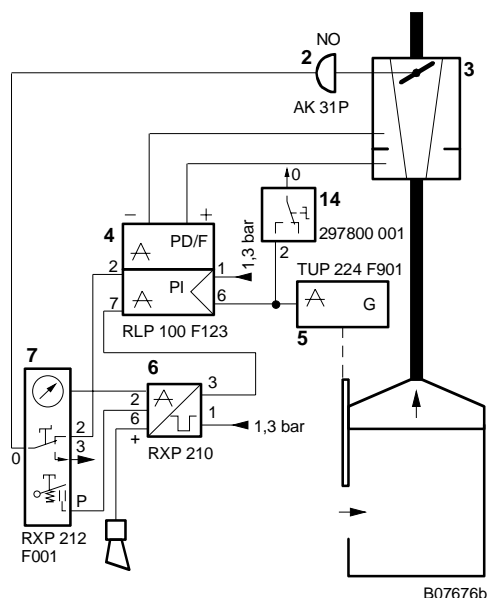

Variant: Fume cupboard with:
– sash detection, continuous
– sliding-door detection for 3 windows, 2-point

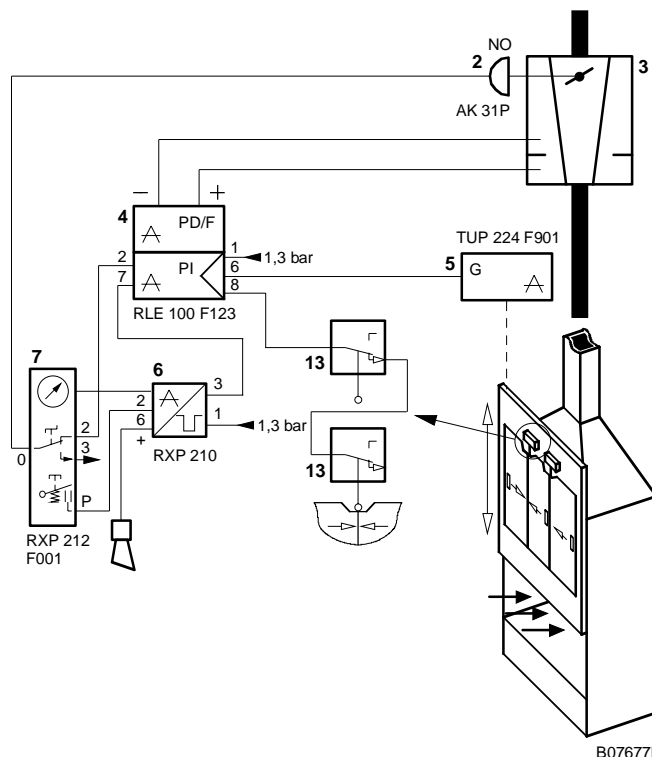

Variant: RLP 100 F123
with: manual switch Aut-min-Aut-max (\checkmark 100 %)
without: alarm and operating units

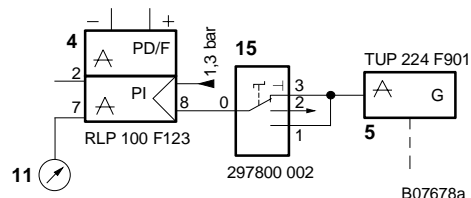

Variant: RLP 100 F123
with: operating unit
without: alarm unit

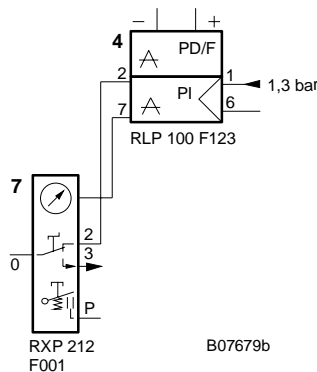

Variant: RLP 100 F123
with: alarm unit
without: operating unit

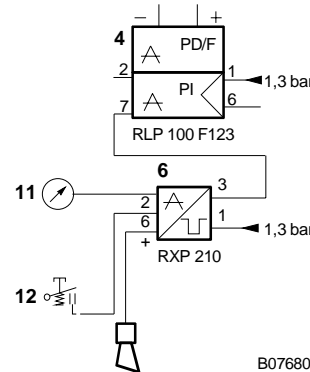

- | | | |
|---|---|---|
| 1 VAV controller | 7 Operating unit | 13 Micro-switch, EVM 131-F01-01S (manuf'd by SMC) |
| 2 Damper drive, NO | 8 VAV exhaust-air contr. for aggressive gases | 14 Manual switch, 0297800 001 |
| 3 Pressure-release unit | 9 Pressure controller | 15 Manual switch, 0297800 002 |
| 4 VAV exhaust-air contr. for fume cupboards | 10 Room temperature controller | 16 e/p - p/e converter |
| 5 Sash sensor | 11 Pressure gauge 0297797 | NO normally open |
| 6 Alarm unit | 12 Mute button, alarm reset | EY Data centre |
| | Micro-valve S0-3-PK-3-B | |
| | Pressure switch AT-06-B (manufac'd by Festo) | |

Архангельск (8182)63-90-72
Астана +7(7172)727-132
Белгород (4722)40-23-64
Брянск (4832)59-03-52
Владивосток (423)249-28-31
Волгоград (844)278-03-48
Вологда (8172)26-41-59
Воронеж (473)204-51-73
Екатеринбург (343)384-55-89
Иваново (4932)77-34-06
Ижевск (3412)26-03-58
Казань (843)206-01-48

Калининград (4012)72-03-81
Калуга (4842)92-23-67
Кемерово (3842)65-04-62
Киров (8332)68-02-04
Краснодар (861)203-40-90
Красноярск (391)204-63-61
Курск (4712)77-13-04
Липецк (4742)52-20-81
Магнитогорск (3519)55-03-13
Москва (495)268-04-70
Мурманск (8152)59-64-93
Набережные Челны (8552)20-53-41

Нижегород (831)429-08-12
Новокузнецк (3843)20-46-81
Новосибирск (383)227-86-73
Орел (4862)44-53-42
Оренбург (3532)37-68-04
Пенза (8412)22-31-16
Пермь (342)205-81-47
Ростов-на-Дону (863)308-18-15
Рязань (4912)46-61-64
Самара (846)206-03-16
Санкт-Петербург (812)309-46-40
Саратов (845)249-38-78

Смоленск (4812)29-41-54
Сочи (862)225-72-31
Ставрополь (8652)20-65-13
Тверь (4822)63-31-35
Томск (3822)98-41-53
Тула (4872)74-02-29
Тюмень (3452)66-21-18
Ульяновск (8422)24-23-59
Уфа (347)229-48-12
Челябинск (351)202-03-61
Череповец (8202)49-02-64
Ярославль (4852)69-52-93