

## RLP 100 F901, F915, F924: Pneumatic room-pressure controller

### How energy efficiency is improved

Enables the precise measurement and control of pressure differentials in clean rooms or laboratories without creating additional pressure compensation openings which lead to unnecessary losses of energy.

### Areas of application

Room pressure control of extremely well-sealed rooms, e.g. clean rooms or laboratories (up to BSL-4).

### Features

- Fast, accurate control system in combination with RLP 100 pneumatic volume-flow controllers
- Highly precise, static sensor, can also be used in areas with contaminated room air
- Measuring ranges up to max. +/- 185 Pa
- ATEX certification for use in Zone 1 potentially explosive areas
- Conformity tested as per EN 13463-1 and EN 1127-1 (Ex II 2 G T6)
- Controller front panel is printed with circuit diagram for rapid identification of function
- Glass-fibre-reinforced thermoplastic housing suitable for wall or top-hat rail mounting (rail EN 60715)
- Compressed-air connections with Rp 1/8" female thread
- Special measuring connection for recording the volume flow with M4 connector
- Low-pressure connections in form of stepped nipples for flexible plastic hose (internal Ø 4 and 6 mm)
- Complies with directive 97/23/EC Art. 3.3 on pressure equipment

### Technical description

- Supply pressure 1.3 bar ± 0.1
- Response sensitivity of sensor 0.1 Pa
- Linearity 1%
- One input for:
  - remote setpoint adjustment
- Two outputs for:
  - actual volume flow value
  - command variable signal for volume-flow controllers
- Setpoint adjuster for room pressure, as well as adjuster for T<sub>n</sub> and X<sub>p</sub>



T1 0000

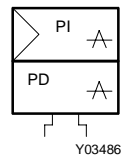

Y03486

Type	Setting range Pa	Air capacity l <sub>n</sub> /h	Weight kg
RLP 100 F901	-20...+20	400	0,6
RLP 100 F915	-50...+50	400	0,6
RLP 100 F924	-180...-35 / +35...+180 <sup>1)</sup>	400	0,6
Output pressure	0,2...1,0 bar	Reset time (0...100%)	0...15 s
Remote setpoint adjust.	0,2...1,0 bar	Linearity	1%
Response sensitivity	<b>F901</b> 0,1 Pa <b>F915</b> 0,25 Pa <b>F924</b> 0,36 Pa	Permiss. operation pressure p <sub>stat</sub>	± 3 kPa
P-band 0...100% ≙	0...40 Pa    0...100 Pa    0...145 Pa	Permissible pressure to the low-pressure connections	± 3 kPa
Supply pressure <sup>2)</sup>	1,3 bar ± 0,1	Connection diagram	<a href="#">A02883</a>
Air consumption	50 l <sub>n</sub> /h	Dimension drawing	<a href="#">M297570</a>
Permissible amb. temp.	0...55 °C	Fitting instructions	<a href="#">MV 505811</a>
Type of protection	IP 30		

### Accessories

- XMP50/50P Pressure gauge, range -50...+50 Pa or -20...+20 Pa (see PDS, Section 68)
- [0297354 000\\*](#) Short screw-type connector (R 1/8") for soft plastic tubing, internal dia. 4 mm; 3 pcs req.
- [0297838 001\\*](#) Bracket for two XMP pressure gauges
- [0297091 000\\*](#) Blanking piece for unused opening in bracket
- [0297867 001\\*](#) Reference pressure container
- [0297870 001\\*](#) Fixing bracket for fitting the controller to ceilings, floors or panels.

<sup>\*)</sup> Dimension drawing or wiring diagram are available under the same number

<sup>1)</sup> Change from measuring over-pressure to under-pressure by transposing the Δp measuring lines

<sup>2)</sup> See Section 60 on regulations concerning the quality of supply air, especially at low ambient temperatures

Архангельск (8182)63-90-72

Астана +7(7172)727-132

Белгород (4722)40-23-64

Брянск (4832)59-03-52

Владивосток (423)249-28-31

Волгоград (844)278-03-48

Вологда (8172)26-41-59

Воронеж (473)204-51-73

Екатеринбург (343)384-55-89

Иваново (4932)77-34-06

Ижевск (3412)26-03-58

Казань (843)206-01-48

Калининград (4012)72-03-81

Калуга (4842)92-23-67

Кемерово (3842)65-04-62

Киров (8332)68-02-04

Краснодар (861)203-40-90

Красноярск (391)204-63-61

Курск (4712)77-13-04

Липецк (4742)52-20-81

Магнитогорск (3519)55-03-13

Москва (495)268-04-70

Мурманск (8152)59-64-93

Набережные Челны (8552)20-53-41

Нижний Новгород (831)429-08-12

Новокузнецк (3843)20-46-81

Новосибирск (383)227-86-73

Орел (4862)44-53-42

Оренбург (3532)37-68-04

Пенза (8412)22-31-16

Пермь (342)205-81-47

Ростов-на-Дону (863)308-18-15

Рязань (4912)46-61-64

Самара (846)206-03-16

Санкт-Петербург (812)309-46-40

Саратов (845)249-38-78

Смоленск (4812)29-41-54

Сочи (862)225-72-31

Ставрополь (8652)20-65-13

Тверь (4822)63-31-35

Томск (3822)98-41-53

Тула (4872)74-02-29

Тюмень (3452)66-21-18

Ульяновск (8422)24-23-59

Уфа (347)229-48-12

Челябинск (351)202-03-61

Череповец (8202)49-02-64

Ярославль (4852)69-52-93

**Operation**

The measured pressure difference is converted by the low-pressure amplifier into the pneumatic standard signal of 0,2...1,0 bar and compared with the variable pressure signal for the setpoint  $X_s$ . The PI-controller compensates without lasting error for the control deviation. The setpoint  $X_s$  set at the controller can be adjusted externally via connection 6, in which case the value set serves as the minimum limitation.

N.B.: The pressure to be controlled should always be connected to the '+' connection, even in the case of under-pressure control. Changing from over- to under-pressure control is realised exclusively by the corresponding setpoint value.

The control action can be changed from B (factory setting) to A using the change-over switch.

**Additional information on accessories**

- 0297838 001** Bracket for two XMP pressure gauges. Includes:  
 1 adaptor (0297596) for tube (internal  $\varnothing$  1,7 or 4,1);  
 1 Connector (0297112) with seal M4/push-on connector for tube (internal  $\varnothing$  1,7);  
 1 m tube (internal  $\varnothing$  1,7) and 2 screws.  
 Use the blanking piece (0297091) to cover the unused opening in the bracket. The pressure gauge for indicating the room pressure should be connected to the actual-value terminal M.

**Engineering and fitting notes**

The unit should not be fitted laterally (as depicted below, right).

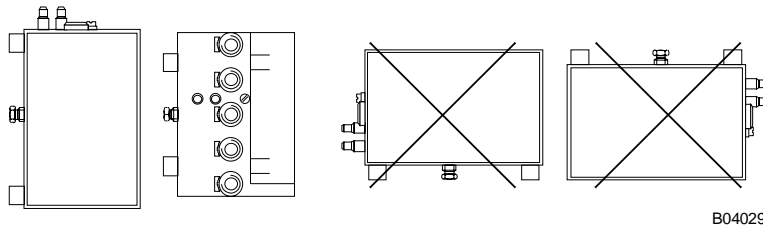

B04029

**Technical information**

Technical manual: VAV 7 000 621 003

**Connection diagram**

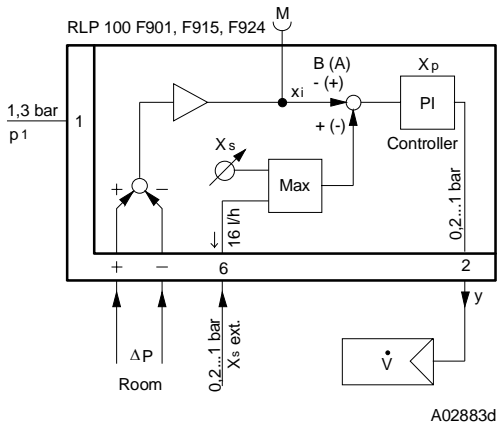

$\Delta p$  = pressure difference  
 y = output pressure

**Dimension drawing**

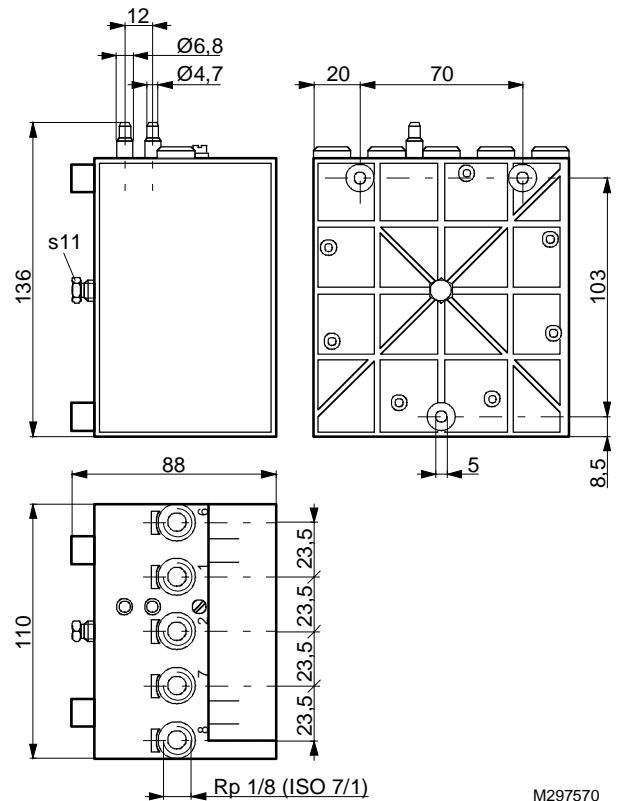

M297570

Accessories

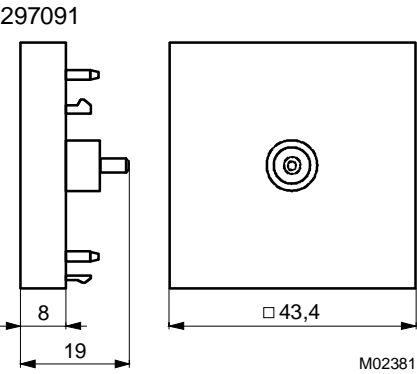
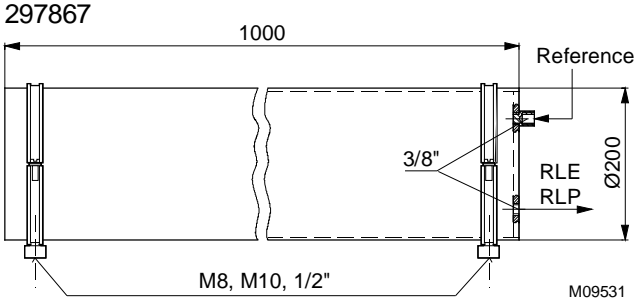
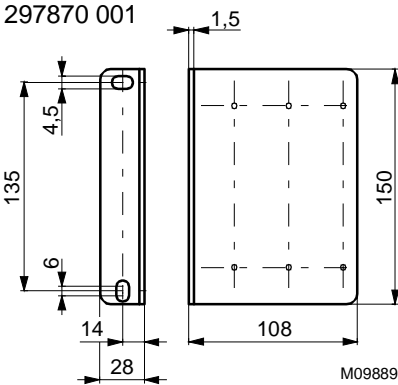
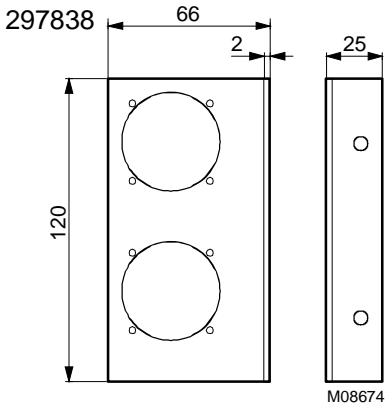
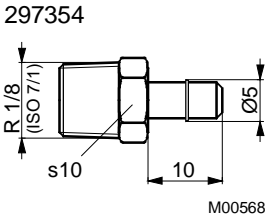

**Examples of use**

- Control facility for variable air volume with re-heater, for 'closed rooms', controlled for over- and/or under-pressure, activating the supply-air controller has controlaction B; normally-open re-heater; room-temperature controller has controlaction A.

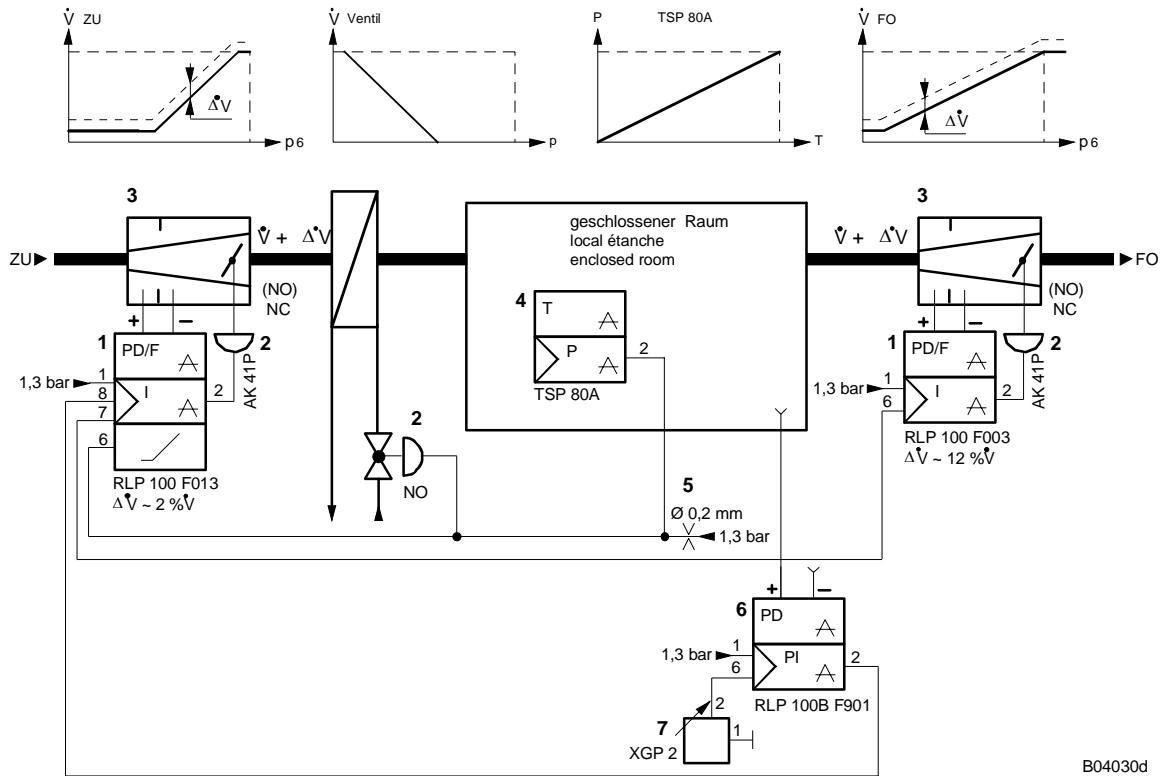

B04030d

- Control facility for variable air volume with re-heater, for 'closed rooms', controlled for over- and/or under-pressure, activating the exhaust-air controller has controlaction A; normally-open re-heater; room-temperature controller has control action A.

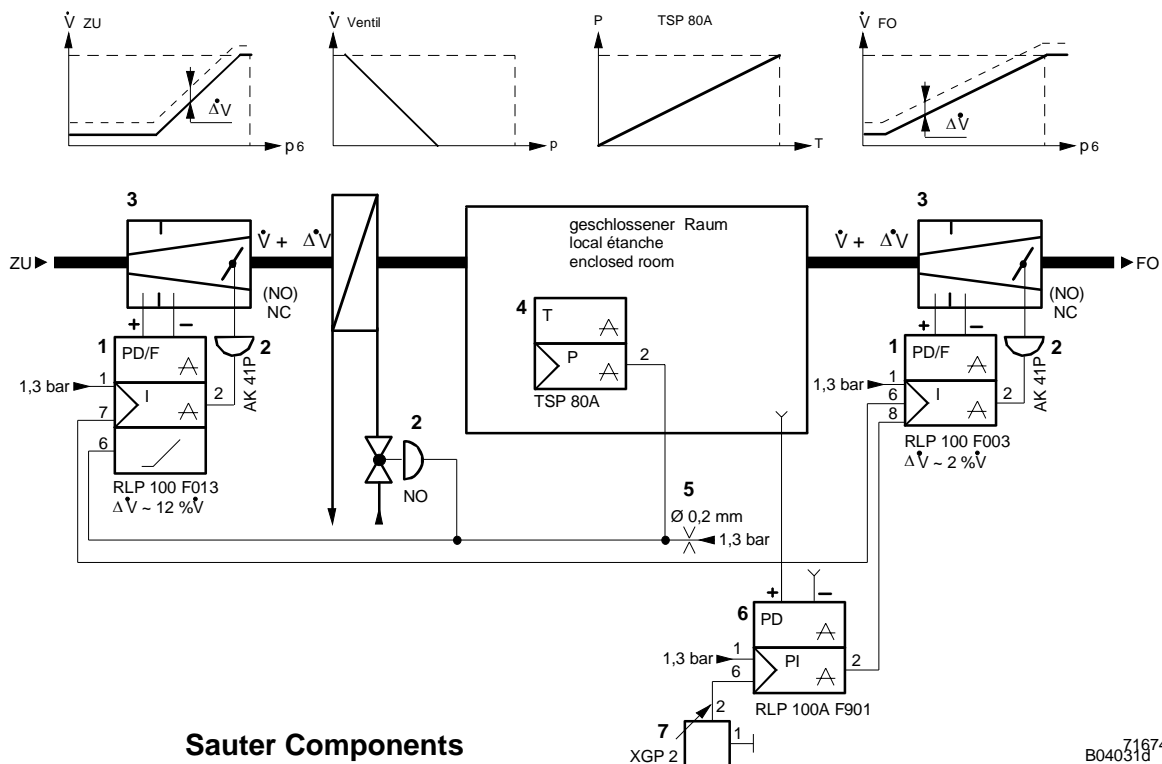

3. Control facility for variable air volume with re-heater, for 'closed rooms', controlled for over- and/or under-pressure, activating the supply-air controller has controlaction B; normally-closed re-heater; room-temperature controller has control action B.

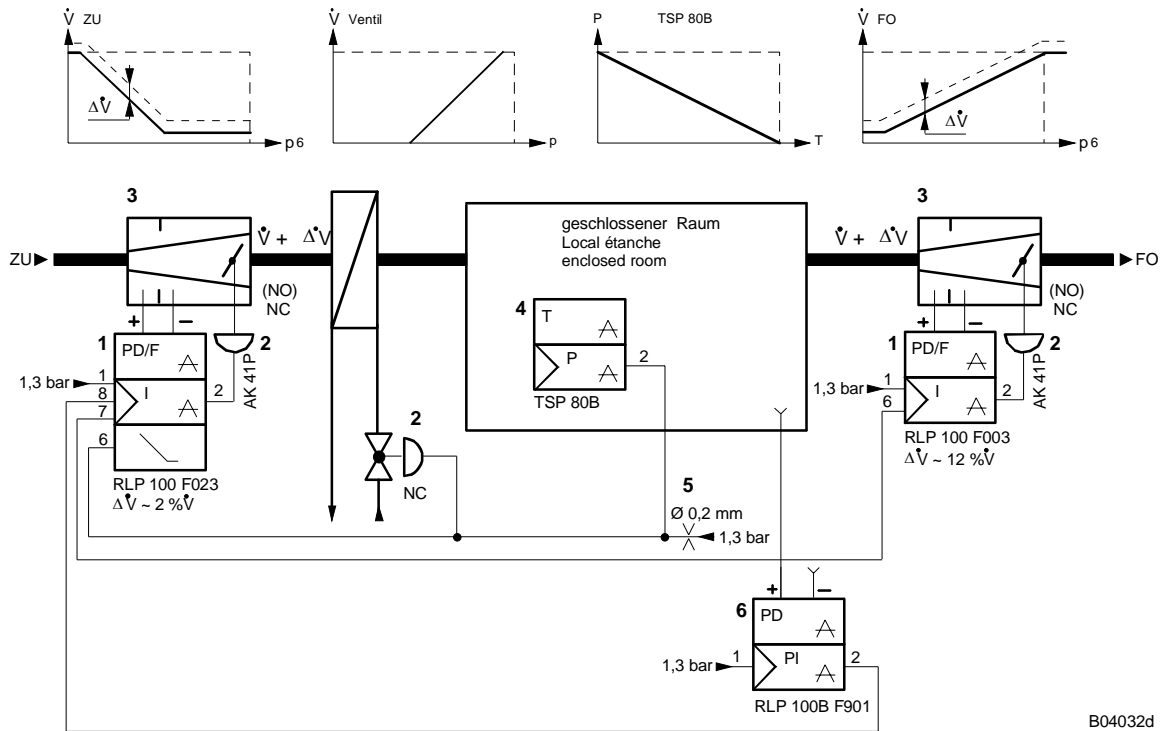

4. Control facility for variable air volume with re-heater, for 'closed rooms', controlled for over- and/or under-pressure, activating the exhaust-air controller has controlaction A; normally-closed re-heater; room-temperature controller has control action B.

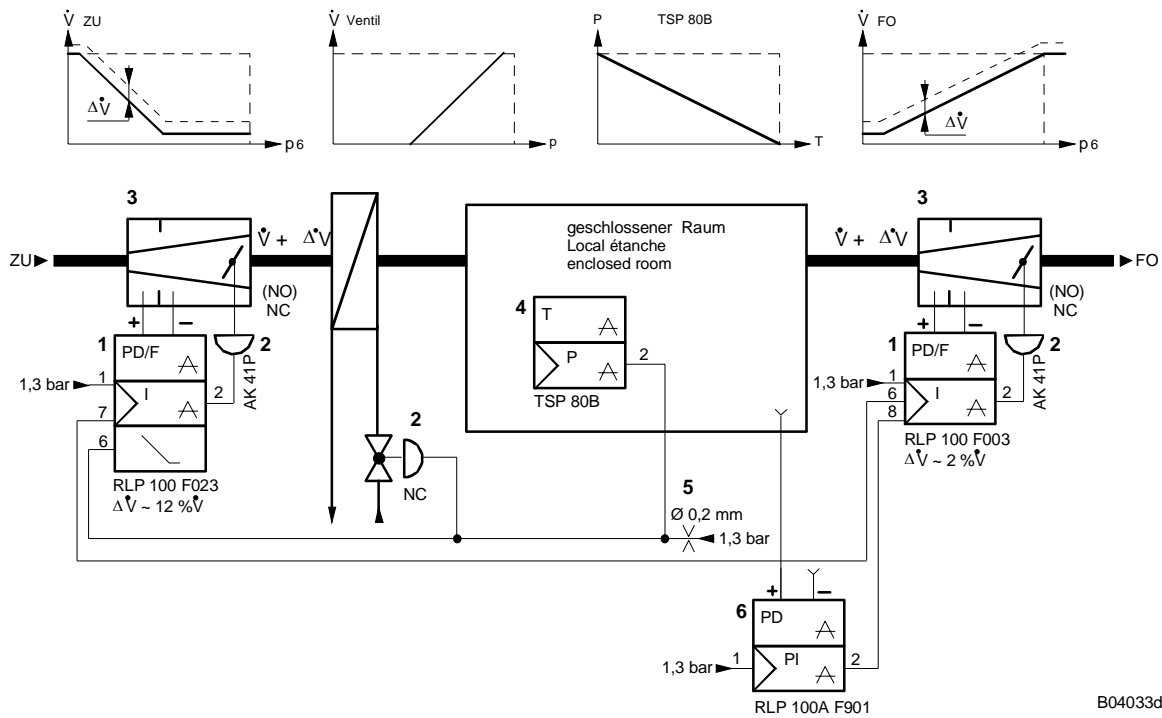

5. Control facility for variable air volume with re-heater, for 'closed rooms', controlled for over- and/or under-pressure, activating the supply-air controller has control action B; normally-open re-heater; room-temperature controller has control action A.

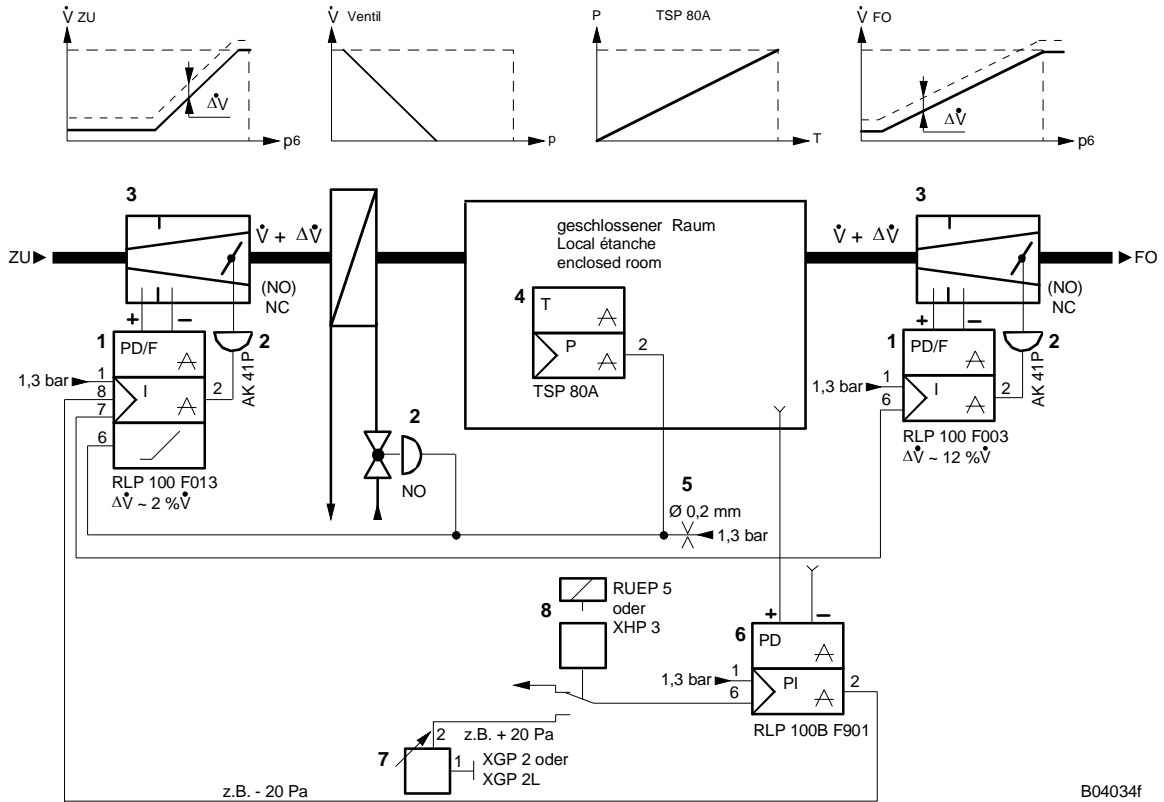

B04034f

1 VAV controller	5 External line restrictor	Ventil Valve
2 Damper/valve drive	6 Pressure controller	FO EA (exhaust air)
3 Pressure-release unit	7 Remote setpoint adjuster	ZU SA ( supply air)
4 Room-temperature controller	8 Manual switch or E-P relay	NO Normally open
		NC Normally closed

Архангельск (8182)63-90-72  
 Астана +7(7172)727-132  
 Белгород (4722)40-23-64  
 Брянск (4832)59-03-52  
 Владивосток (423)249-28-31  
 Волгоград (844)278-03-48  
 Вологда (8172)26-41-59  
 Воронеж (473)204-51-73  
 Екатеринбург (343)384-55-89  
 Иваново (4932)77-34-06  
 Ижевск (3412)26-03-58  
 Казань (843)206-01-48

Калининград (4012)72-03-81  
 Калуга (4842)92-23-67  
 Кемерово (3842)65-04-62  
 Киров (8332)68-02-04  
 Краснодар (861)203-40-90  
 Красноярск (391)204-63-61  
 Курск (4712)77-13-04  
 Липецк (4742)52-20-81  
 Магнитогорск (3519)55-03-13  
 Москва (495)268-04-70  
 Мурманск (8152)59-64-93  
 Набережные Челны (8552)20-53-41

Нижний Новгород (831)429-08-12  
 Новокузнецк (3843)20-46-81  
 Новосибирск (383)227-86-73  
 Орел (4862)44-53-42  
 Оренбург (3532)37-68-04  
 Пенза (8412)22-31-16  
 Пермь (342)205-81-47  
 Ростов-на-Дону (863)308-18-15  
 Рязань (4912)46-61-64  
 Самара (846)206-03-16  
 Санкт-Петербург (812)309-46-40  
 Саратов (845)249-38-78

Смоленск (4812)29-41-54  
 Сочи (862)225-72-31  
 Ставрополь (8652)20-65-13  
 Тверь (4822)63-31-35  
 Томск (3822)98-41-53  
 Тула (4872)74-02-29  
 Тюмень (3452)66-21-18  
 Ульяновск (8422)24-23-59  
 Уфа (347)229-48-12  
 Челябинск (351)202-03-61  
 Череповец (8202)49-02-64  
 Ярославль (4852)69-52-93

Единый адрес для всех регионов: [sxr@nt-rt.ru](mailto:sxr@nt-rt.ru) || [www.sauter.nt-rt.ru](http://www.sauter.nt-rt.ru)