

HSUP: Room transducer for relative humidity

How energy efficiency is improved

Accurate recording of air humidity in pneumatic installations for optimal control of HVAC systems.

Areas of application

Continuous measurement and/or control of relative humidity in combination with pneumatic control equipment (Centair), e.g. in rooms.

Features

- Part of the Centair family of systems
- Conversion of relative humidity into a standard 0.2 to 1.0 bar pneumatic signal
- Lid in thermoplastic with grey/white frame (RAL 9002) and pure-white front panel (RAL 9010)
- Compressed-air connection on plug nipple for flexible plastic hose int. \varnothing 4 mm
- Complies with directive 97/23/EC Art. 3.3 on pressure equipment

Technical description

- Supply pressure 1.3 bar \pm 0.1
- Nozzle/ball system
- Linearity of output signal < 2%

Type	Measuring range %rh	Output pressure bar	Weight kg
HSUP 1 F001	20...90	0,2...1,0	0,17
Supply pressure ¹⁾ (via ext. restrictor of \varnothing 0,2 mm)	1,3 \pm 0,1 bar	Effect of temperature	-0,5% rh/K
Air capacity, air consumption	33 l _n /h	Permissible ambient temp.	10...40 °C
Max. hysteresis	5% rh	Connection diagram	A02782
Linearity	see characteristic	Dimension drawing	M303048
Time constant (0,2 m/s)	approx. 10 min	Fitting instructions	MV 2427

Accessories

- 0296218 000*** Buckle-proof adaptor for push-on connection
0296990 000* Buckle-proof adaptor for screw-on connection, MV 7322
0303124 000* Recessed junction box
0310315 000* Surface junction box

*) Dimension drawing or wiring diagram are available under the same number

1) In the RCP and RPP 20 controllers, the restrictors (\varnothing 0,2 mm) are fitted at inputs 3 and 4.
See Section 60 on regulations concerning the quality of supply air, especially at low ambient temperatures.

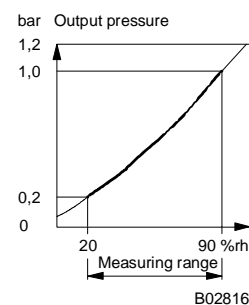
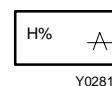

Operation

As the humidity increases, the nylon band expands, thereby creating a stroke on the lever system. This stroke is converted by the conversion spring into a force. The bleed-off nozzle-ball system converts this force into an equivalent pressure change. As the humidity increases, the output pressure rises.

Engineering and fitting notes

The effect of temperature can easily be negated by making the necessary adjustment of the hexagonal screw at the end of the lever. Since the measuring span is unaffected by either fitting or use, the tension of the spring converter should not be altered.

Архангельск (8182)63-90-72
Астана +7(7172)727-132
Белгород (4722)40-23-64
Брянск (4832)59-03-52
Владивосток (423)249-28-31
Волгоград (844)278-03-48
Вологда (8172)26-41-59
Воронеж (473)204-51-73
Екатеринбург (343)384-55-89
Иваново (4932)77-34-06
Ижевск (3412)26-03-58
Казань (843)206-01-48

Калининград (4012)72-03-81
Калуга (4842)92-23-67
Кемерово (3842)65-04-62
Киров (8332)68-02-04
Краснодар (861)203-40-90
Красноярск (391)204-63-61
Курск (4712)77-13-04
Липецк (4742)52-20-81
Магнитогорск (3519)55-03-13
Москва (495)268-04-70
Мурманск (8152)59-64-93
Набережные Челны (8552)20-53-41

Нижний Новгород (831)429-08-12
Новокузнецк (3843)20-46-81
Новосибирск (383)227-86-73
Орел (4862)44-53-42
Оренбург (3532)37-68-04
Пенза (8412)22-31-16
Пермь (342)205-81-47
Ростов-на-Дону (863)308-18-15
Рязань (4912)46-61-64
Самара (846)206-03-16
Санкт-Петербург (812)309-46-40
Саратов (845)249-38-78

Смоленск (4812)29-41-54
Сочи (862)225-72-31
Ставрополь (8652)20-65-13
Тверь (4822)63-31-35
Томск (3822)98-41-53
Тула (4872)74-02-29
Тюмень (3452)66-21-18
Ульяновск (8422)24-23-59
Уфа (347)229-48-12
Челябинск (351)202-03-61
Череповец (8202)49-02-64
Ярославль (4852)69-52-93

Единый адрес для всех регионов: sxr@nt-rt.ru || www.sauter.nt-rt.ru

Technical information

Technical manual: *centair* system 304991 003

Output pressure as a function of the relative humidity at 23 °C

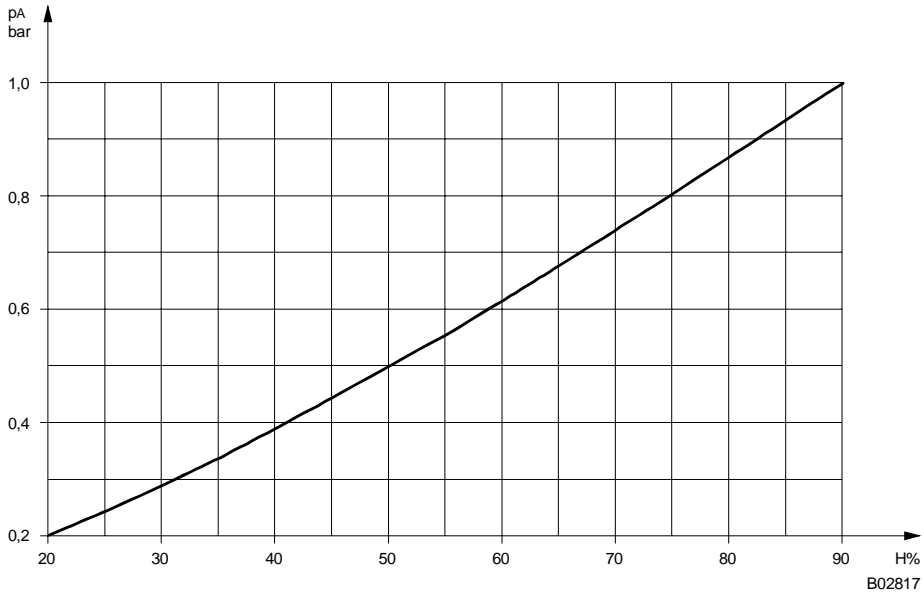

Connection diagram

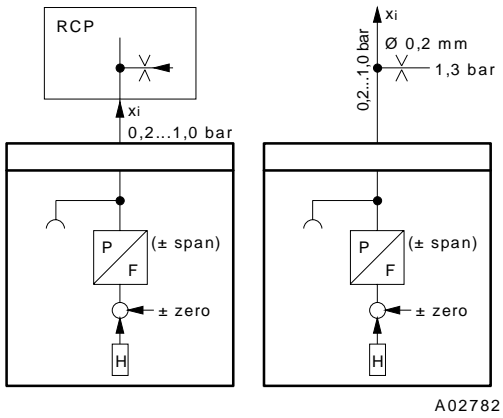

Dimension drawing

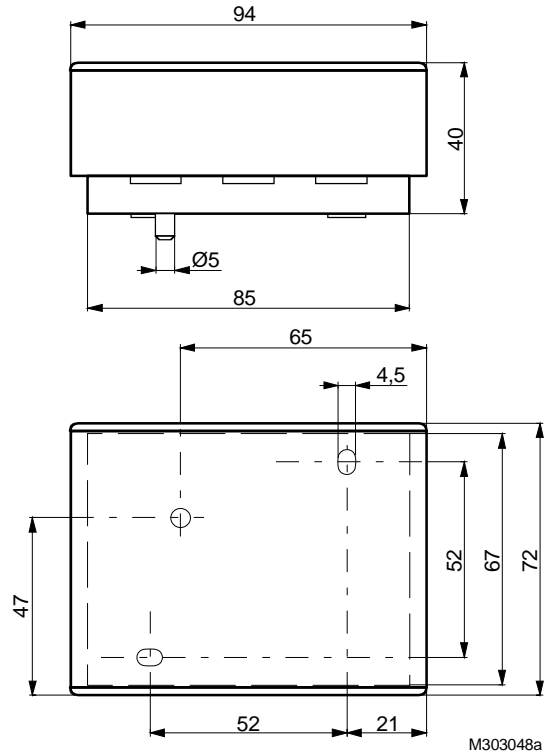

Accessories

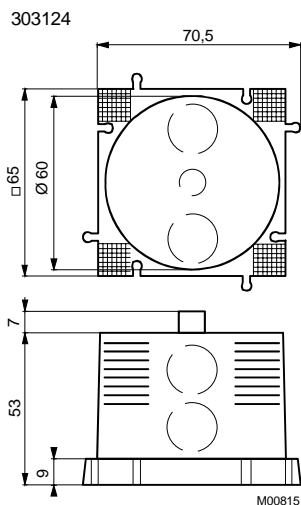
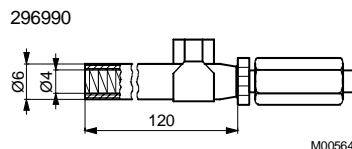
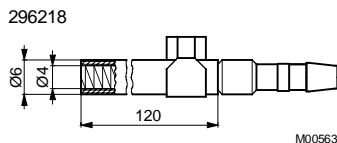
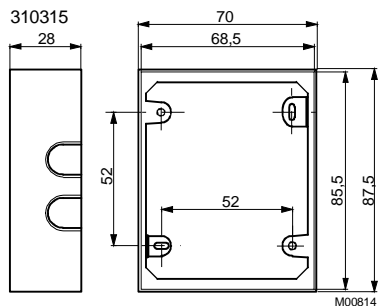

Архангельск (8182)63-90-72
 Астана +7(7172)727-132
 Белгород (4722)40-23-64
 Брянск (4832)59-03-52
 Владивосток (423)249-28-31
 Волгоград (844)278-03-48
 Вологда (8172)26-41-59
 Воронеж (473)204-51-73
 Екатеринбург (343)384-55-89
 Иваново (4932)77-34-06
 Ижевск (3412)26-03-58
 Казань (843)206-01-48

Калининград (4012)72-03-81
 Калуга (4842)92-23-67
 Кемерово (3842)65-04-62
 Киров (8332)68-02-04
 Краснодар (861)203-40-90
 Красноярск (391)204-63-61
 Курск (4712)77-13-04
 Липецк (4742)52-20-81
 Магнитогорск (3519)55-03-13
 Москва (495)268-04-70
 Мурманск (8152)59-64-93
 Набережные Челны (8552)20-53-41

Нижний Новгород (831)429-08-12
 Новокузнецк (3843)20-46-81
 Новосибирск (383)227-86-73
 Орел (4862)44-53-42
 Оренбург (3532)37-68-04
 Пенза (8412)22-31-16
 Пермь (342)205-81-47
 Ростов-на-Дону (863)308-18-15
 Рязань (4912)46-61-64
 Самара (846)206-03-16
 Санкт-Петербург (812)309-46-40
 Саратов (845)249-38-78

Смоленск (4812)29-41-54
 Сочи (862)225-72-31
 Ставрополь (8652)20-65-13
 Тверь (4822)63-31-35
 Томск (3822)98-41-53
 Тула (4872)74-02-29
 Тюмень (3452)66-21-18
 Ульяновск (8422)24-23-59
 Уфа (347)229-48-12
 Челябинск (351)202-03-61
 Череповец (8202)49-02-64
 Ярославль (4852)69-52-93

Единый адрес для всех регионов: sxr@nt-rt.ru || www.sauter.nt-rt.ru