

modu572: I/O Модуль, аналоговые выходы, универсальные и цифровые входы
Как повышается энергетическая эффективность

Технология SAUTER EY-modulo 5 : модульная, быстрая, универсальная

Область применения

Регулирование с помощью стандартного сигнала (0...10 V), регистрация цифровых входов (сигнал/статус) и аналоговых входов (Ni/Pt1000, U/I/Pot) в технических установках, например, HVAC

Характеристики

- Встраиваемый элемент для расширения станции автоматизации modu525
- 4 выхода
- 11 входов
- Модульный дизайн (базовая плата/электроника)
- Питание от автоматической станции modu525
- Маркировка непосредственно на передней панели
- Часть семейства систем SAUTER EY-modulo
- Возможность подключения к местным ручным/индикационным приборам

Техническое описание

- 4 аналоговых выхода (0...10 V)
- 8 универсальных входов (Ni/Pt1000, U/I/R, DI)
- 3 цифровые входы (DI фиксированы)

Продукт

Тип	Описание
EY-IO572F001	I/O Модуль, аналоговые выходы, цифровые и универсальные входы

Техническая информация
Электропитание

Питание	от modu525 через шину I/O
Потребляемая мощность ¹⁾	до 1.5 VA, 0.8 W
Рассеиваемая мощность	до 0.80 W
Потребляемый ток ²⁾	до 120 mA

Варианты

Аналоговые (0...10V/0...20 mA)	выходы	4 (источники)
Нагрузка		до 20 mA
Универсальные входы		8
Аналоговые		Ni/Pt1000, U/I/R, Pot
Цифровые		DI (до 3 Hz)
Цифровые входы		3, фиксированное расположение
Счетчик импульсов		до 10 Hz

Интерфейс, связь

Соединение, modu6 . . (LOI)	6-контактное, интегрированное
Соединение, I/O -шина	2-контактное, интегрированное
Соединительные клеммы	24, 0.5...2.5 mm ²

Допустимые окружающие условия

Рабочая температура	0...45 °C
Температура хранения и транспортировки	-25...70 °C
Влажность	10...85% rh без конденсации

1) На первой стороне базовой станции modu525 (230 V~)

2) Питание через базовую станцию modu525

Установка

Монтаж	на динрейку
Размеры ДхВхГ (мм)	42 x 170 x 115
Вес (кг)	0.285

Стандарты, нормативы и директивы

Степень защиты	IP 30 (EN 60529)
Класс защиты	I (EN 60730-1)
Окружающий класс	3К3 (IEC 60721)
СЕ соответствие	
Директива EMC 2004/108/EC	EN 61000-6-1 EN 61000-6-2 EN 61000-6-3 EN 61000-6-4

Дополнительная информация

Инструкция по монтажу электроники	P100001574
Инструкция по монтажу с базовой платой	P100001575
Декларация материалов	MD 92.061
Размерные чертежи	M11416
Электросхема	A10595



T110601

Архангельск (8182)63-90-72
 Астана +7(7172)727-132
 Белгород (4722)40-23-64
 Брянск (4832)59-03-52
 Владивосток (423)249-28-31
 Волгоград (844)278-03-48
 Вологда (8172)26-41-59
 Воронеж (473)204-51-73
 Екатеринбург (343)384-55-89
 Иваново (4932)77-34-06
 Ижевск (3412)26-03-58
 Казань (843)206-01-48

Калининград (4012)72-03-81
 Калуга (4842)92-23-67
 Кемерово (3842)65-04-62
 Киров (8332)68-02-04
 Краснодар (861)203-40-90
 Красноярск (391)204-63-61
 Курск (4712)77-13-04
 Липецк (4742)52-20-81
 Магнитогорск (3519)55-03-13
 Москва (495)268-04-70
 Мурманск (8152)59-64-93
 Набережные Челны (8552)20-53-41

Нижний Новгород (831)429-08-12
 Новокузнецк (3843)20-46-81
 Новосибирск (383)227-86-73
 Орел (4862)44-53-42
 Оренбург (3532)37-68-04
 Пенза (8412)22-31-16
 Пермь (342)205-81-47
 Ростов-на-Дону (863)308-18-15
 Рязань (4912)46-61-64
 Самара (846)206-03-16
 Санкт-Петербург (812)309-46-40
 Саратов (845)249-38-78

Смоленск (4812)29-41-54
 Сочи (862)225-72-31
 Ставрополь (8652)20-65-13
 Тверь (4822)63-31-35
 Томск (3822)98-41-53
 Тула (4872)74-02-29
 Тюмень (3452)66-21-18
 Ульяновск (8422)24-23-59
 Уфа (347)229-48-12
 Челябинск (351)202-03-61
 Череповец (8202)49-02-64
 Ярославль (4852)69-52-93

Engineering notes

The modu572 I/O module generally consists of two components: the baseplate, in which the I/O bus system and connection terminals are integrated, and the actual I/O module electronics.

Installation and assembly

The baseplate of the I/O module is fitted to a top-hat rail (EN 60715) inside a motor control centre and connected on one side directly with the I/O bus of the modu525 automation station or modules. This connection work must be done with the power switched off.

The baseplate contains the 'bus module' that is responsible for the power supply and continuous communication. This ensures that disturbances due to a malfunction or partial defect of the electronic component do not affect the functionality of other modules in the sequence.

I/O modules can be inserted into, and removed from, the baseplate whilst the automation station is in operation.

In order to protect the installation and to avoid input/output malfunctions, I/O modules should be inserted or removed only when the base station is switched off.

Labelling concept

The I/O module can be labelled by means of a paper insert behind the transparent cover on the front side. These labels are normally inscribed using text generated from within CASE Suite and are printed out on normal DIN A4 paper using generic printers.

Assigning modules to an automation station

The I/O electronic module has hardware pin coding so that only the corresponding baseplate can be used. The modu525 automation station detects whether a module baseplate is plugged into the I/O bus. CASE Suite is used to assign the baseplate number and module types of I/O modules to the automation station. This information is stored permanently in the automation station.

LED indicators & function

The I/O module is equipped with a system LED that indicates the following operating conditions:

System LED

LED I/O bus	Condition	Indicator sequence	Description
No name	green continuous	—————	Module in operation
	green pulsating	• • • •	Module not assigned to base station
	red pulsating fast	••••••••••	AS in configuration, update or download mode
	red flashing	• • • • • •	Module incorrectly assigned or internal error
	alternating green, red, off	•• •• •• ••	Lamp test active (display type has priority)
	no display		No power supply

Description of function

The I/O module has a total of 4 analogue outputs, eight universal and 3 digital inputs

Outputs

Number of outputs 4
 Type of outputs Analogue outputs 0(2)...10 V=
 or 0...20 mA
 Load up to 20 mA (source) per output
 Return line wired to earth

The output voltage is tapped between an output terminal (a0...a3) and a ground terminal. The outputs are designed as pure sources and can be loaded at up to 20 mA. Change-over to a current signal is automatic and dependent on load.

The outputs are protected against static discharge, but not against d.c. or a.c.

Universal inputs

Number of inputs 8 (UI)
 Type of inputs Ni1000 (DIN 43760)
 (Software coding) Pt1000 (IEC 751)
 Voltage measurement (U)
 Current measurement (I) ch. u8, u9 only
 Potentiometer input (Pot)
 Resistance (R)

Scan rate
 100 ms channels u8, u12
 500 ms channels u9, u10, u11, u13, u14, u15

Measuring ranges
 Voltage (U) 0 (2)...10 V, 0 (0.2)...1 V
 Current (I) 0 (4)...20 mA
 Potentiometer (Pot) 0...1 (100%) with 3-wire connection
 (1...2.5 kΩ)
 Reference Uref 1.23 V (terminal no. 22)
 >1 kΩ, load max. 10 mA
 Resistance (R) 200...2500 Ω
 Temperature Ni1000 -50...+150 °C
 Pt1000 -50...+150 °C

Digital input potential-free contacts, wired to earth
 opto-coupler, transistor (open collector)
 approx. I_{out} = 1.2 mA
 Pulse meter max. 3 Hz (100 ms update interval)
 max. 0.5 Hz (500 ms update interval)
 Protection against extraneous voltage
 Ni/Pt/U/R/Pot/DI ± 30 V / 24 V~ (without damage)
 I (channels u12, u13) +12 V, -0.3 V (without damage)
 Reference Uref 1.23 V (terminal no. 22)

Temperature measurement (Ni/Pt)

The Ni/Pt1000 sensors are connected using the two-wire method between one of the input terminals for universal inputs (channel u8...u15) and an earth terminal. Inputs do not require calibration and can be used directly. A corresponding line resistance of 2 Ω is pre-compensated as standard. With a corresponding line resistance of 2 Ω (cross-section: 1.5 mm²), the power cable (wire) may be up to 85 m in length. Greater line resistances can be compensated using the software. The measuring voltage is pulsed so that the sensor does not heat up (I_{Meas} approx. 0.3 mA).

Voltage measurement (U)

The voltage should be measured between one of the input terminals for universal inputs (channels u8...u15) and an earthing terminal. The signal must be potential-free. The measurement ranges with or without offset 0 (0.2)...1 V or 0 (2)...10 V are selected via the software. The input's internal resistance R_i (load) is 9 MΩ.

Current measurement (I)

The current can be measured at two inputs only. The current is measured between one of the two input terminals for universal inputs (channel u8, u9) and an earth terminal. The current signal must be potential-free. The measurement ranges with or without offset 0 (4)...20 mA are selected via the software. The maximum input current must be restricted to 50 mA; the internal resistance R_i is < 50 Ω.

Potentiometer measurement (Pot)

The potentiometer is connected between one of the input terminals for universal inputs (channel u8, u9), an earthing terminal and the U_{ref} terminal (reference voltage). So as not to overload the reference output, the lowest potentiometer value should be at least 1 kΩ. The reference output is not short-circuit-proof. The upper value of 2.5 kΩ is prescribed in order to guarantee stable measurement free of interference.

Note In order to maintain the measuring accuracy, earthing connections should be occupied with the same type of input.

Digital inputs (DI with UI)

The AS also uses the universal inputs to record binary information. This information (alarm/status) is connected between an input terminal (u8... u15) and an earthing terminal. The station applies a voltage of approx. 13 V to the terminal. This usually corresponds to INACTIVE (bit=0) for open contacts. When the contacts are closed, they are ACTIVE (bit=1) and 0 V is applied; the current is approx. 1 mA. Brief temporary changes (Default 33 ms) are buffered between the station's polling enquiries and are then processed in the next cycle.

Each input can be set as an alarm or a status by configuring the software accordingly.

Digital inputs can be indicated on a local indicating unit (e.g. modu630).

Digital inputs (DI fixed)

Number of inputs 3

Type of inputs	potential-free contacts, wired to earth opto-coupler transistor (open collector)
Pulse meter	up to 10 Hz (100 ms scan rate)
Pulse length	> 4 ms
Protection against extraneous voltage	±30 V/24 V~ (without damage)
Max. output current	1.2 mA with respect to earth
Scan rate	100 ms

Binary information is connected between one of the input terminals (d5...d7) and earth. The module applies approximately 13 V to the terminal. This corresponds to INACTIVE (bit=0) for open contacts. When the contacts are closed, it is ACTIVE (bit=1) and 0 V is applied, and the current is approx. 1 mA. Brief temporary changes (Default 33 ms) are buffered between the station's polling enquiries and are then processed in the next cycle.

Each input can be set as an alarm or a status by configuring the software accordingly.

Digital inputs can be indicated on a local indicating unit (e.g. modu630).

Pulse counter (CI with DI)

Counter inputs for potential-free contacts, opto-couplers or transistors with an open collector can be connected to the digital inputs. The maximum pulse frequency may reach 50 Hz. To ensure that switched contacts are registered correctly, provision is made for a de-bounce time of 5 ms. Pulses can be detected on falling, rising or both edges; the minimum pulse time should be four times the de-bounce time.

Technical specification of inputs and outputs

Universal input	Measuring range	Resolution	Accuracy	
			of measuring span plus measurement value	
Ni/Pt1000	-50...+150 °C	< 0.05 K	± 0.5%	0.5%
U (0/0,2...1 V)	0.02...1.1 V	< 0.1 mV	± 0.5%	0.5%
U (0/2...10 V)	0.15...10.2 V	< 1 mV	± 0.5%	0.5%
I (0/4...20 mA)	0.02...22 mA	< 0.02 mA	± 1%	2%
R	200...2500 Ω	< 0,1 Ω	± 0,2%	1%
Pot (> 1 kΩ)	1...100%	< 0,5%	± 1%	1%

Analogue outputs	Positioning range		Slope error	
AO (0/2...10 V / 0...20 mA)	0.01...10.2 V	< 2 mV	1%	1%

Binary input (0-I)	Universal input (UI)	Digital input (DI)
Switching threshold, active	> 3 V	> 4 V
Switching threshold, inactive	< 1.5 V	< 2.5 V
Switching hysteresis	> 0.4 V	> 0.4 V

Channels and terminals

Description	Channel	Wiring diagram	Signal	Terminals	
					GND
Analogue output (0...10 V)	0	a0	2		1
	1	a1	4		3
	2	a2	6		5
	3	a3	8		7
Digital input (Pulse counter CI)	5	d5	10		9
	6	d6	11		
	7	d7	12		
Universal input (Ni/Pt1000/U/I/R/Pot)	8	u8	13		
	9	u9	14		
	10	u10	15		16
	11	u11	17		18
	12	u12	19		20
Current measurement (I) channel 8, 9 or terminals 13, 14 only	13	u13	21		
	14	u14	23		
	15	u15	24		
Reference voltage 1.23 V		Ref	22		

Connecting a local override unit

A modu670 local indicating unit (LOI: Local Override and Indication device) can be added to the modu572 I/O module to enable direct activation of positioning signals and indication of digital outputs.

The modu630 local indicating unit can also be used.

The unit can be fitted or removed during ongoing operations (hot-plug capability) without affecting any functions of either the automation station or the I/O module.

Detailed information on the control functions and the LED indicators can be found in PDS 92.081.



All the LEDs (red + yellow) will flash if an incompatible override unit is connected; there is no danger of damaging the I/O module.

Note

Before use, all the controller positions (auto) should be checked to ensure that no undesirable signal values are issued. On removing the unit, all outputs are run using the automatic values of the automation station or the I/O module.

In keeping with the applicable standard, the local override and indication devices allow the restricted operation of plant components without involving the automation station intended for the application. If any of the outputs of either the automation station or the I/O module are in the manual position, they may temporarily change value while a user program is being downloaded. The local override unit can be used to control the analogue outputs directly in the automation station even without a user application (CASE Engine).

Accessories

EY-LO630F001	Single unit used for indicating data points for I/O module modu572 or AS modu525		
	16 LEDs	LED indicators, bi-colour green/red (freely configurable for event/alarm)	
EY-LO670F001	Single unit used for indicating data points for I/O module modu572 or AS modu525		
	8 LEDs	LED indicators, bi-colour green/red (freely configurable for event/alarm)	
	4 sliding switches with LED indicator	Setpoint transmitter 0...100%, indicating manual position, yellow LED indicator, red (freely configurable for event/alarm)	

Wiring diagram

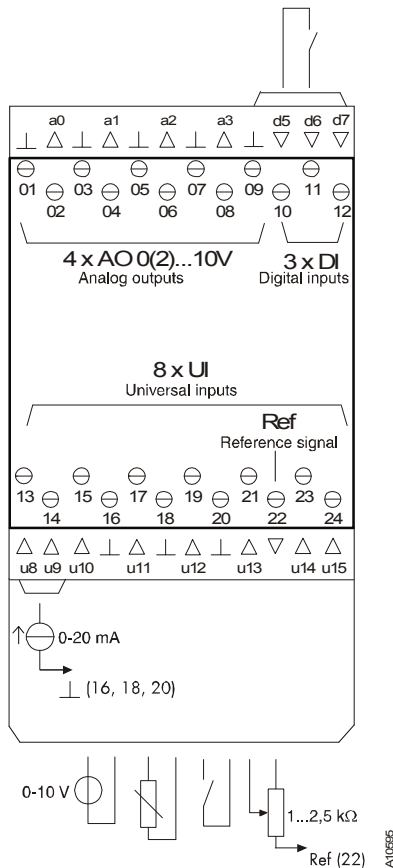

Dimension drawing

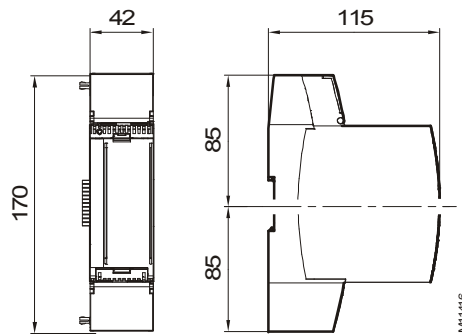

Архангельск (8182)63-90-72
Астана +7(7172)727-132
Белгород (4722)40-23-64
Брянск (4832)59-03-52
Владивосток (423)249-28-31
Волгоград (844)278-03-48
Вологда (8172)26-41-59
Воронеж (473)204-51-73
Екатеринбург (343)384-55-89
Иваново (4932)77-34-06
Ижевск (3412)26-03-58
Казань (843)206-01-48

Калининград (4012)72-03-81
Калуга (4842)92-23-67
Кемерово (3842)65-04-62
Киров (8332)68-02-04
Краснодар (861)203-40-90
Красноярск (391)204-63-61
Курск (4712)77-13-04
Липецк (4742)52-20-81
Магнитогорск (3519)55-03-13
Москва (495)268-04-70
Мурманск (8152)59-64-93
Набережные Челны (8552)20-53-41

Нижний Новгород (831)429-08-12
Новокузнецк (3843)20-46-81
Новосибирск (383)227-86-73
Орел (4862)44-53-42
Оренбург (3532)37-68-04
Пенза (8412)22-31-16
Пермь (342)205-81-47
Ростов-на-Дону (863)308-18-15
Рязань (4912)46-61-64
Самара (846)206-03-16
Санкт-Петербург (812)309-46-40
Саратов (845)249-38-78

Смоленск (4812)29-41-54
Сочи (862)225-72-31
Ставрополь (8652)20-65-13
Тверь (4822)63-31-35
Томск (3822)98-41-53
Тула (4872)74-02-29
Тюмень (3452)66-21-18
Ульяновск (8422)24-23-59
Уфа (347)229-48-12
Челябинск (351)202-03-61
Череповец (8202)49-02-64
Ярославль (4852)69-52-93

Единый адрес для всех регионов: sxr@nt-rt.ru || www.sauter.nt-rt.ru